



EBARA

SHINWA
COOLING TOWER

EBARA
OPEN CIRCUIT CROSS FLOW SQUARE TYPE
SHINWA COOLING TOWER

Model SDC-U
Model SNC-U

Standard Cooling Tower

※Model xxx in this catalogue is our model code



PVC

Grey (mancel N-7)



Selection - Standard Specifications - Noise Level

Standard Condition

Water flow rate : 13 ℓ / (min · 4.535kW)、Water temp : Inlet=37°C, Out=32°C, W.B.=27°C

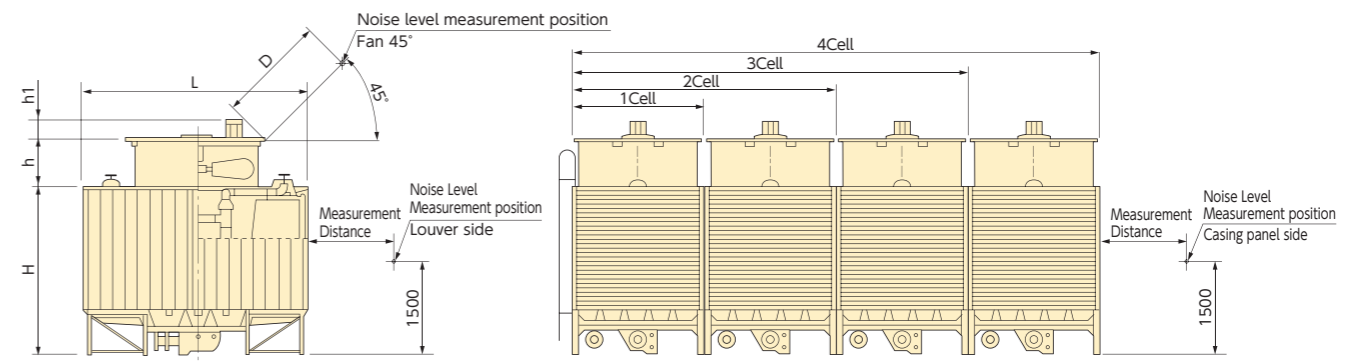

Specification			HL [m]	Dimensions [mm]					Mass.[kg]		Cells	Fan · Motor 3Ph.400V 50/60Hz							Piping Size [A]					Noise Level [dB(A)]				
Inlet Temp. (°C)	37			L	W	H	h	h1	Shipping	Operation		Dia [mm]	kW [kW]	P [P]	Drv	Amp [A]		Q'ty	In	Out	Ov	Dr	Ba	Ma	Q'ty	Fan 45° Dm	Louver side H=1.5m 2m	Casing Panel Side H=1.5m 2m
Outlet Temp. (°C)	32															50Hz	60Hz											
WB. Temp. (°C)	27	28		Water Flow[ℓ/min]																								
SDC-U50ASSD	650	559	3	2490	1350	2140	415	60	450	1000	1/1	1000	1.0	10/12	DD	3.4	4.0	1	100	100	40	40	25	25	1	62.0	55.5	52.0
75ASSD	975	839	3	2690	1550	2140	460	90	500	1200		1200	1.5	12/14	DD	6.9	6.6	1	100	100	40	40	25	25	1	63.5	57.5	53.5
85ASSD	1,105	950	3	2690	1550	2140	460	90	510	1210		1200	2.2	10/12	DD	7.3	7.3	1	100	100	40	40	25	25	1	64.5	58.5	54.5
100ASSD	1,300	1,118	3	2990	1850	2140	270	367	590	1510		1500	2.2	4	BD	5.3	4.9	1	125	125	40	40	25	25	1	65.0	59.0	55.0
125ASSD	1,645	1,415	3	2990	1850	2140	270	389	600	1520		1500	3.7	4	BD	8.0	7.6	1	125	125	40	40	25	25	1	66.0	60.5	56.5
150ASSD	1,950	1,703	4	3270	1750	2770	615	389	840	2290		1/2	1500	3.7	4	BD	8.0	7.6	1	125	125	50	50	32	32	1	65.5	60.0
175ASSD	2,275	1,987	4	3270	1950	2770	615	439	910	2500	1500		5.5	4	BD	11.9	10.5	1	125	125	50	50	32	32	1	66.5	61.0	57.5
200ASSD	2,600	2,271	4	3570	2150	2770	645	439	1020	2910	1800		5.5	4	BD	11.9	10.5	1	150	150	50	50	32	32	1	66.0	61.0	56.5
225ASSD	2,925	2,555	4	3870	2350	2770	715	449	1130	3220	2100		5.5	4	BD	11.9	10.5	1	150	150	50	50	32	32	1	66.5	62.0	57.0
250ASSD	3,250	2,839	4	3870	2350	2770	715	497	1150	3240	2100		7.5	4	BD	15.9	14.1	1	150	150	50	50	32	32	1	67.5	63.0	60.0
300ASSD	3,900	3,406	4	3270	3500	2770	615	389	1640	4540	2/4		1500	3.7	4	BD	8.0	7.6	2	125	125	50	50	32	32	2	67.5	62.5
350ASSD	4,550	3,974	4	3270	3900	2770	615	439	1780	4960		1500	5.5	4	BD	11.9	10.5	2	125	125	50	50	32	32	2	68.5	63.5	59.0
400ASSD	5,200	4,543	4	3570	4300	2770	645	439	2010	5790		1800	5.5	4	BD	11.9	10.5	2	150	150	50	50	32	32	2	68.0	63.5	58.0
450ASSD	5,850	5,111	4	3870	4700	2770	715	449	2220	6400		2100	5.5	4	BD	11.9	10.5	2	150	150	50	50	32	32	2	68.5	64.5	58.5
500ASSD	6,500	5,678	4	3870	4700	2770	715	497	2260	6440		2100	7.5	4	BD	15.9	14.1	2	150	150	50	50	32	32	2	69.5	65.5	61.5
600ASSD	7,800	6,815	4	3570	6450	2770	645	439	3000	8670		3/6	1800	5.5	4	BD	11.9	10.5	3	150	150	50	50	32	32	3	69.0	65.0
700ASSD	9,750	8,518	4	3870	7050	2770	715	497	3370	9640	2100		7.5	4	BD	15.9	14.1	3	150	150	50	50	32	32	3	70.5	67.0	62.5
800ASSD	10,400	9,086	4	3570	8600	2770	645	439	3990	11550	4/8	1800	5.5	4	BD	11.9	10.5	4	150	150	50	50	32	32	4	69.5	65.5	59.5
900ASSD	11,700	10,222	4	3870	9400	2770	715	449	4400	12760		2100	5.5	4	BD	11.9	10.5	4	150	150	50	50	32	32	4	70.0	66.5	60.0
1000ASSD	13,000	11,357	4	3870	9400	2770	715	497	4480	12840		2100	7.5	4	BD	15.9	14.1	4	150	150	50	50	32	32	4	71.0	67.5	63.0

- Noise level at fan 45° point shows at 45° and fan diameter away from surface of fan casing.
 - In case of a fan diameter < 1.5m, the noise level at 45° point is 1.5m away.
- HL: Head Loss, L: Length, W: Width, H: Tower Height, h: Fan Casing Height, h1: Motor Height

In: Water Inlet, Out: Water Outlet, Ov: Over Flow, Dr: Drain, Ba: Automatic Make-up, Ma: Manual Make-up, Drv: Driving Method, DD: Direct Drive, BD: Belt Drive, Amp: Rated Current, Dm: Fan 45° Diameter Point

Selection - Standard Specifications - Noise Level

Standard Condition

Water flow rate : 13 ℓ / (min · 4.535kW)、Water temp : Inlet=37°C, Out=32°C, W.B.=27°C

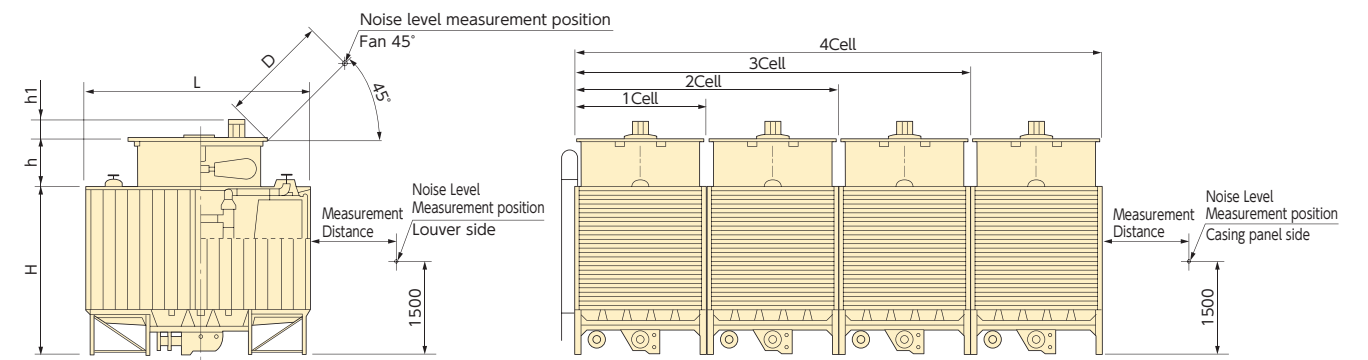

Specification			HL [m]	Dimensions [mm]					Mass.[kg]		Cells	Fan · Motor 3Ph.400V 50/60Hz							Piping Size [A]						Noise Level [dB(A)]			
Inlet Temp. (°C)	37			L	W	H	h	h1	Shipping	Operation		Dia [mm]	kW [kW]	P [P]	Drv	Amp [A]		Q'ty	In	Out	Ov	Dr	Ba	Ma	Q'ty	Fan 45° Dm	Louver side H=1.5m 2m	Casing Panel Side H=1.5m 2m
Outlet Temp. (°C)	32															50Hz	60Hz											
WB. Temp. (°C)	27	28		Water Flow[ℓ/min]																								
SDC-U50ASD	650	559	3	2490	1350	2140	415	60	440	990	1/1	1000	1.0	10/12	DD	3.4	4.0	1	100	100	40	40	25	25	1	65.0	60.0	56.0
75ASD	975	839	3	2690	1550	2140	460	90	490	1190		1200	1.5	12/14	DD	6.9	6.6	1	100	100	40	40	25	25	1	66.5	61.5	57.5
85ASD	1,105	950	3	2690	1550	2140	460	90	500	1200		1200	2.2	10/12	DD	7.3	7.3	1	100	100	40	40	25	25	1	67.5	62.5	58.5
100ASD	1,300	1,118	3	2990	1850	2140	270	367	580	1500		1500	2.2	4	BD	5.3	4.9	1	125	125	40	40	25	25	1	68.0	63.0	59.0
125ASD	1,645	1,415	3	2990	1850	2140	270	389	590	1510		1500	3.7	4	BD	8.0	7.6	1	125	125	40	40	25	25	1	69.0	64.5	60.5
150ASD	1,950	1,703	4	3270	1750	2770	615	389	830	2280	1/2	1500	3.7	4	BD	8.0	7.6	1	125	125	50	50	32	32	1	68.5	63.0	59.0
175ASD	2,275	1,987	4	3270	1950	2770	615	439	900	2490		1500	5.5	4	BD	11.9	10.5	1	125	125	50	50	32	32	1	69.5	64.0	60.5
200ASD	2,600	2,271	4	3570	2150	2770	645	439	1010	2900		1800	5.5	4	BD	11.9	10.5	1	150	150	50	50	32	32	1	68.5	63.5	59.0
225ASD	2,925	2,555	4	3870	2350	2770	715	449	1110	3200		2100	5.5	4	BD	11.9	10.5	1	150	150	50	50	32	32	1	69.0	64.5	59.5
250ASD	3,250	2,839	4	3870	2350	2770	715	497	1130	3220		2100	7.5	4	BD	15.9	14.1	1	150	150	50	50	32	32	1	70.0	65.5	62.5
300ASD	3,900	3,406	4	3270	3500	2770	615	389	1620	4520	2/4	1500	3.7	4	BD	8.0	7.6	2	125	125	50	50	32	32	2	70.5	65.5	60.5
350ASD	4,550	3,974	4	3270	3900	2770	615	439	1760	4940		1500	5.5	4	BD	11.9	10.5	2	125	125	50	50	32	32	2	71.5	66.5	62.0
400ASD	5,200	4,543	4	3570	4300	2770	645	439	1990	5770		1800	5.5	4	BD	11.9	10.5	2	150	150	50	50	32	32	2	70.5	66.0	60.5
450ASD	5,850	5,111	4	3870	4700	2770	715	449	2180	6360		2100	5.5	4	BD	11.9	10.5	2	150	150	50	50	32	32	2	71.0	67.0	61.0
500ASD	6,500	5,678	4	3870	4700	2770	715	497	2220	6400		2100	7.5	4	BD	15.9	14.1	2	150	150	50	50	32	32	2	72.0	68.0	64.0
600ASD	7,800	6,815	4	3570	6450	2770	645	439	2970	8640	3/6	1800	5.5	4	BD	11.9	10.5	3	150	150	50	50	32	32	3	71.5	67.5	61.5
700ASD	9,750	8,518	4	3870	7050	2770	715	497	3310	9580		2100	7.5	4	BD	15.9	14.1	3	150	150	50	50	32	32	3	73.0	69.5	65.0
800ASD	10,400	9,086	4	3570	8600	2770	645	439	3950	11510	4/8	1800	5.5	4	BD	11.9	10.5	4	150	150	50	50	32	32	4	72.0	68.0	62.0
900ASD	11,700	10,222	4	3870	9400	2770	715	449	4320	12680		2100	5.5	4	BD	11.9	10.5	4	150	150	50	50	32	32	4	72.5	69.0	62.5
1000ASD	13,000	11,357	4	3870	9400	2770	715	497	4400	12760		2100	7.5	4	BD	15.9	14.1	4	150	150	50	50	32	32	4	73.5	70.0	65.5

- Noise level at fan 45° point shows at 45° and fan diameter away from surface of fan casing.
 - In case of a fan diameter < 1.5m, the noise level at 45° point is 1.5m away.
- HL: Head Loss, L: Length, W: Width, H: Tower Height, h: Fan Casing Height, h1: Motor Height

In: Water Inlet, Out: Water Outlet, Ov: Over Flow, Dr: Drain, Ba: Automatic Make-up, Ma: Manual Make-up, Drv: Driving Method, DD: Direct Drive, BD: Belt Drive, Amp: Rated Current, Dm: Fan 45° Diameter Point

Selection - Standard Specifications - Noise Level

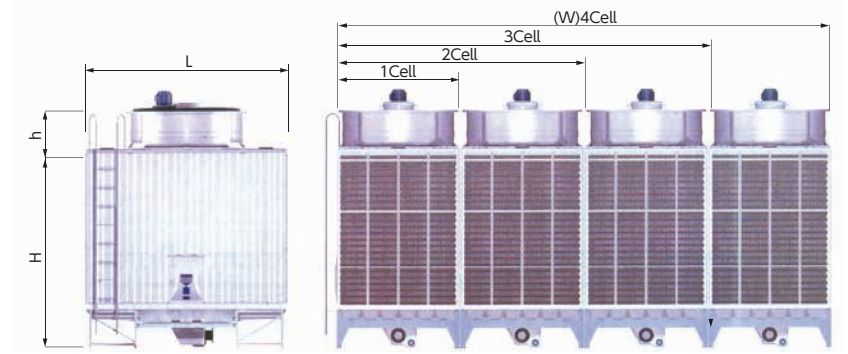

*Other voltages such as 380, 415V are available on request

Specification		Inlet Temp. (°C)		Outlet Temp. (°C)		WB. Temp. (°C)		Dimensions [mm]	Piping Size [A]					Q'ty	Mass.(kg)		Motor for Fan 3Ph × 400V × 50Hz*						Noise Level [dB(A)]						
Model	Water Flow[ℓ/min]	L	W	H	h	In	Out		Ov	Dr	Ba	Ma	Shipping		Operation	Dia mm φ	kW	P	Drv	Amp [A]	Q'ty	Fan 45°	Louver side H=1.5m			Casing Panel Side H=1.5m			
																						Dm	2m	10m	16m	2m	10m	16m	
EXTERNAL PIPING TYPE	SNC-U280ASSY	2535	1778	3570	2150	3790	645	-	150	50	50	32	32	1	1280	3380	1800	7.5	4	BD	16.3	1	70	65	57.5	53	61	54	50.5
	320ASSY	3244	2275	3870	2350	3790	715	-	150	50	50	32	32	1	1400	3750	2100	7.5	4	BD	16.3	1	71.5	66.5	59	65.5	62.5	55.5	52
	350ASSY	3622	2540	3870	2350	3790	715	-	150	50	50	32	32	1	1440	3790	2100	11.0	4	BD	21.3	1	72.5	67.5	60	56.5	63.5	66.5	63
	560ASSY	5070	3556	3570	4300	3790	645	-	150	50	50	32	32	2	2450	6650	1800	7.5	4	BD	16.3	2	72	67	59.5	56	63	56	52.5
	640ASSY	6488	4550	3870	4700	3790	715	-	150	50	50	32	32	2	2690	7390	2100	7.5	4	BD	16.3	2	74	69	61.5	58	65	58	54.5
	700ASSY	7244	5080	3870	4700	3790	715	-	150	50	50	32	32	2	2770	7470	2100	11.0	4	BD	21.3	2	75	70	62.5	59	66	59	55.5
	840ASSY	7605	5334	3570	6450	3790	645	-	150	50	50	32	32	3	3620	9920	1800	7.5	4	BD	16.3	3	73	68	60.5	57	64	57	53.5
	960ASSY	9732	6825	3870	7050	3790	715	-	150	50	50	32	32	3	3980	11030	2100	7.5	4	BD	16.3	3	74.5	70	62.5	59	66	59	55.5
	1050ASSY	10866	7620	3870	7050	3790	715	-	150	50	50	32	32	3	4100	11150	2100	11.0	4	BD	21.3	3	75.5	71	63.5	60	67	60	56.5
	1120ASSY	10140	7112	3570	8600	3790	645	-	150	50	50	32	32	4	4790	13190	1800	7.5	4	BD	16.3	4	73.5	69.5	62	58.5	65.5	58.5	55
	1280ASSY	12976	9100	3870	9400	3790	715	-	150	50	50	32	32	4	5270	14670	2100	7.5	4	BD	16.3	4	75	71	63.5	60	67	60	56.5
1400ASSY	14488	10160	3870	9400	3790	715	-	150	50	50	32	32	4	5430	14830	2100	11.0	4	BD	21.3	4	76	72	64.5	61	68	61	57.5	
INTERNAL PIPING TYPE	SNC-U280ASSD	2535	1778	3570	2150	3790	645	150	150	50	50	32	32	1	1330	3430	1800	7.5	4	BD	16.3	1	70	65	57.5	53	61	54	50.5
	320ASSD	3244	2275	3870	2350	3790	715	150	150	50	50	32	32	1	1450	3800	2100	7.5	4	BD	16.3	1	71.5	66.5	59	65.5	62.5	55.5	52
	350ASSD	3622	2540	3870	2350	3790	715	150	150	50	50	32	32	1	1480	3830	2100	11.0	4	BD	21.3	1	72.5	67.5	60	56.5	63.5	66.5	63
	560ASSD	5070	3556	3570	4300	3790	645	150	150	50	50	32	32	2	2540	6740	1800	7.5	4	BD	16.3	2	72	67	59.5	56	63	56	52.5
	640ASSD	6488	4550	3870	4700	3790	715	150	150	50	50	32	32	2	2780	7480	2100	7.5	4	BD	16.3	2	74	69	61.5	58	65	58	54.5
	700ASSD	7244	5080	3870	4700	3790	715	150	150	50	50	32	32	2	2850	7550	2100	11.0	4	BD	21.3	2	75	70	62.5	59	66	59	55.5
	840ASSD	7605	5334	3570	6450	3790	645	150	150	50	50	32	32	3	3750	10050	1800	7.5	4	BD	16.3	3	73	68	60.5	57	64	57	53.5
	960ASSD	9732	6825	3870	7050	3790	715	150	150	50	50	32	32	3	4110	11160	2100	7.5	4	BD	16.3	3	74.5	70	62.5	59	66	59	55.5
	1050ASSD	10866	7620	3870	7050	3790	715	150	150	50	50	32	32	3	4220	11270	2100	11.0	4	BD	21.3	3	75.5	71	63.5	60	67	60	56.5
	1120ASSD	10140	7112	3570	8600	3790	645	150	150	50	50	32	32	4	4960	13360	1800	7.5	4	BD	16.3	4	73.5	69.5	62	58.5	65.5	58.5	55
	1280ASSD	12976	9100	3870	9400	3790	715	150	150	50	50	32	32	4	5440	14840	2100	7.5	4	BD	16.3	4	75	71	63.5	60	67	60	56.5
	1400ASSD	14488	10160	3870	9400	3790	715	150	150	50	50	32	32	4	5590	14990	2100	11.0	4	BD	21.3	4	76	72	64.5	61	68	61	57.5

• Noise level at fan 45° point shows at 45° and fan diameter away from surface of fan casing.
 • In case of a fan diameter < 1.5m, the noise level at 45° point is 1.5m away.
 HL: Head Loss, L: Length, W: Width, H: Tower Height, h: Fan Casing Height, h1: Motor Height

In: Water Inlet, Out: Water Outlet, Ov: Over Flow, Dr: Drain, Ba: Automatic Make-up, Ma: Manual Make-up, Drv: Driving Method, BD: Belt Drive, Amp: Rated Current, Dm: Fan 45° Diameter Point

Standard Cooling Tower

Feature

1 Energy Saving, Space Saving Compactness and Lightweight

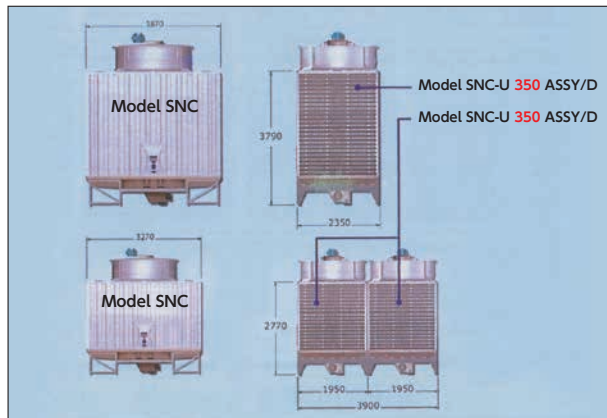

New development such as high efficiency fill type eliminator and cone shaped fan casing are built in. Combination of super low noise fan reduces an installation space and volume as well as dry & wet weight about 20% compared with previous models.

2 Built-In Piping Arrangements



"U" series cooling towers are supplied with built-in piping arrangements as standard. The result is cost-and-space saving and safety of the installation work. (Outside piping arrangements are also available.)

3 Easier Maintenance

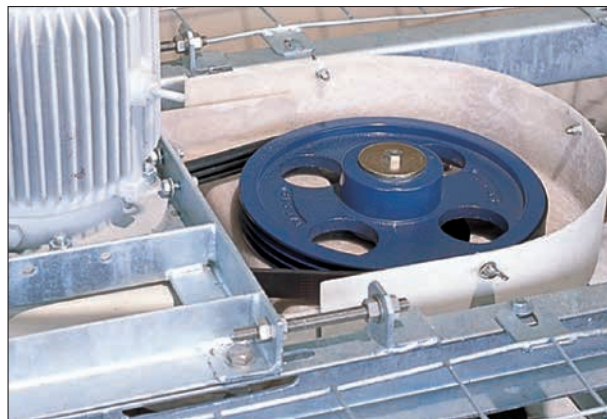

A new speed reducer with wedge belt is compact and easy for maintenance. Also, FRP lower water basin is sloped for easy cleaning. Except direct connection motor model. (Belt cover is removed on this photo.)

4 Reduced Installation Time



"U" series cooling towers cover the ranges from 50RT to 1000RT. Delivery can be made in complete assembled or semi-assembled unit form. The installation time at site can be greatly reduced by this method.

Semi Assembled Unit Form (Main Body + Fan Casing)

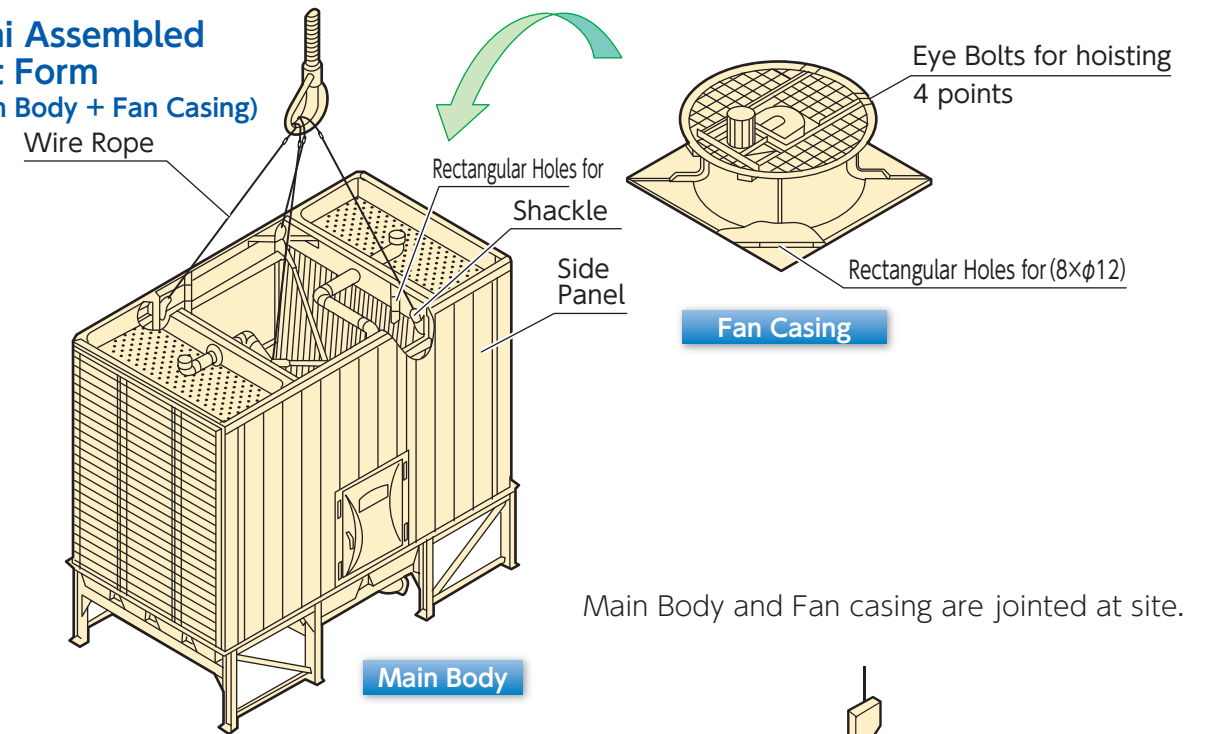

Main Body and Fan casing are jointed at site.

Standard Cooling Tower

Model SDC-U For Turbo Chiller	Main Body		Fan Casing	
	Weight(kg)	Q'ty	Weight(kg)	Q'ty
-	620	1	200	1
150	620	1	200	1
-	650	1	240	1
175	650	1	240	1
-	730	1	270	1
200	730	1	270	1
-	780	1	330	1
225	780	1	330	1
250	780	1	350	1
-	620	2	200	2
300	620	2	200	2
-	650	2	240	2
350	650	2	240	2
-	730	2	270	2
400	730	2	270	2
-	780	2	330	2
450	780	2	330	2
500	780	2	350	2
-	650	3	240	3
-	730	3	270	3
600	730	3	270	3
-	780	3	330	3
-	780	3	330	3
700	780	3	350	3
-	730	4	270	4
800	730	4	270	4
-	780	4	330	4
900	780	4	330	4
1000	780	4	350	4

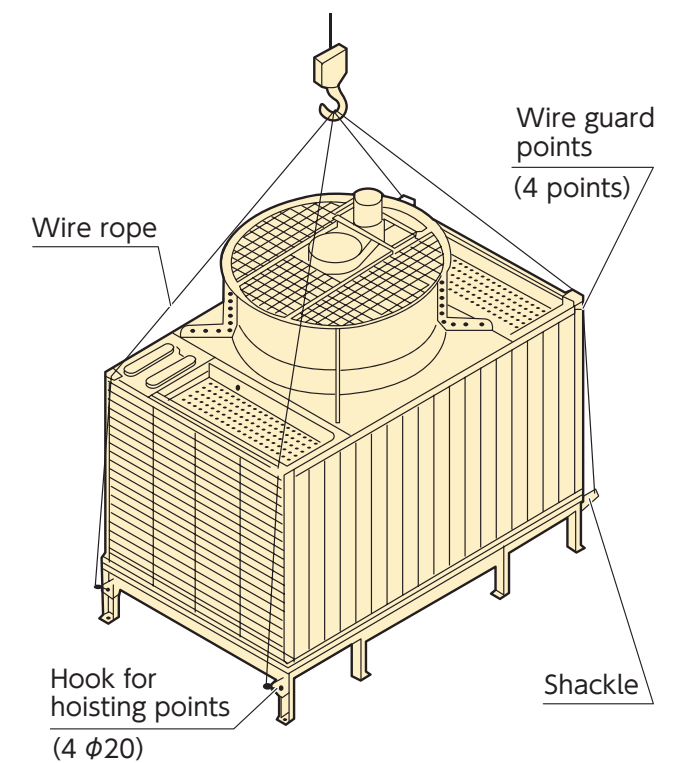

Assemble Unit Form (One Unit)

Model SDC-U for Turbo Chiller	Main Body	
	Weight(kg)	Q'ty
50	450	1
75	500	1
85	510	1
100	590	1
125	600	1

Standard Cooling Tower

Structure Model SDC-U

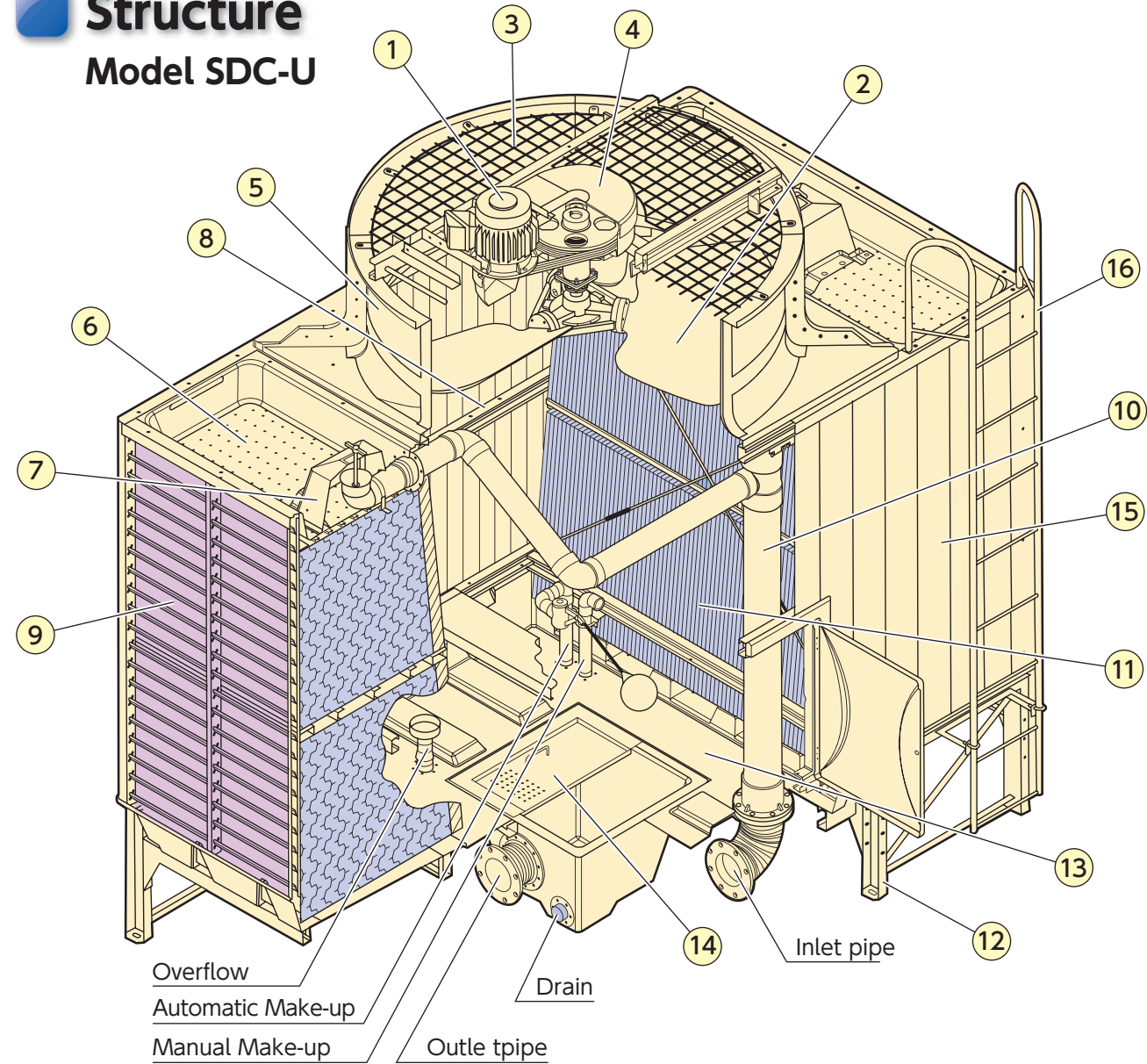

No.	Parts Name	Material	Q'ty	Remarks
1	Motor		1Pc	Total Enclosed Outdoor
2	Fan	Alum. Alloy Cast	1Set	
3	Fan Guard	H.D.G. Steel	1Set	Hot Dip Galvanized
4	Belt Cover	F.R.P.	1Set	
5	Fan Casing	F.R.P.	1Set	
6	Upper Water Basin	F.R.P.	2Pc	
7	Sprinkler Cover	F.R.P.	2Pc	With Simple Water Level Adjustment Valve
8	Frame Works	H.D.G. Steel	1Set	Hot Dip Galvanized

No.	Parts Name	Material	Q'ty	Remarks
9	Louver	P.V.C.	2Side	
10	Inlet Piping	P.V.C.	1Set	
11	Fill	P.V.C.	1Set	
12	Lower Frame	H.D.G. Steel	1Set	Hot Dip Galvanized
13	Lower Water Basin	F.R.P.	1Set	Inclined
14	Strainer	H.D.G. Steel	1Pc	Hot Dip Galvanized
15	Casing Panel	P.V.C.	2Side	
16	Ladder	H.D.G. Steel	1Pc	Hot Dip Galvanized

Standard color: Grey (mancel N-7)

Structure Model SNC-U

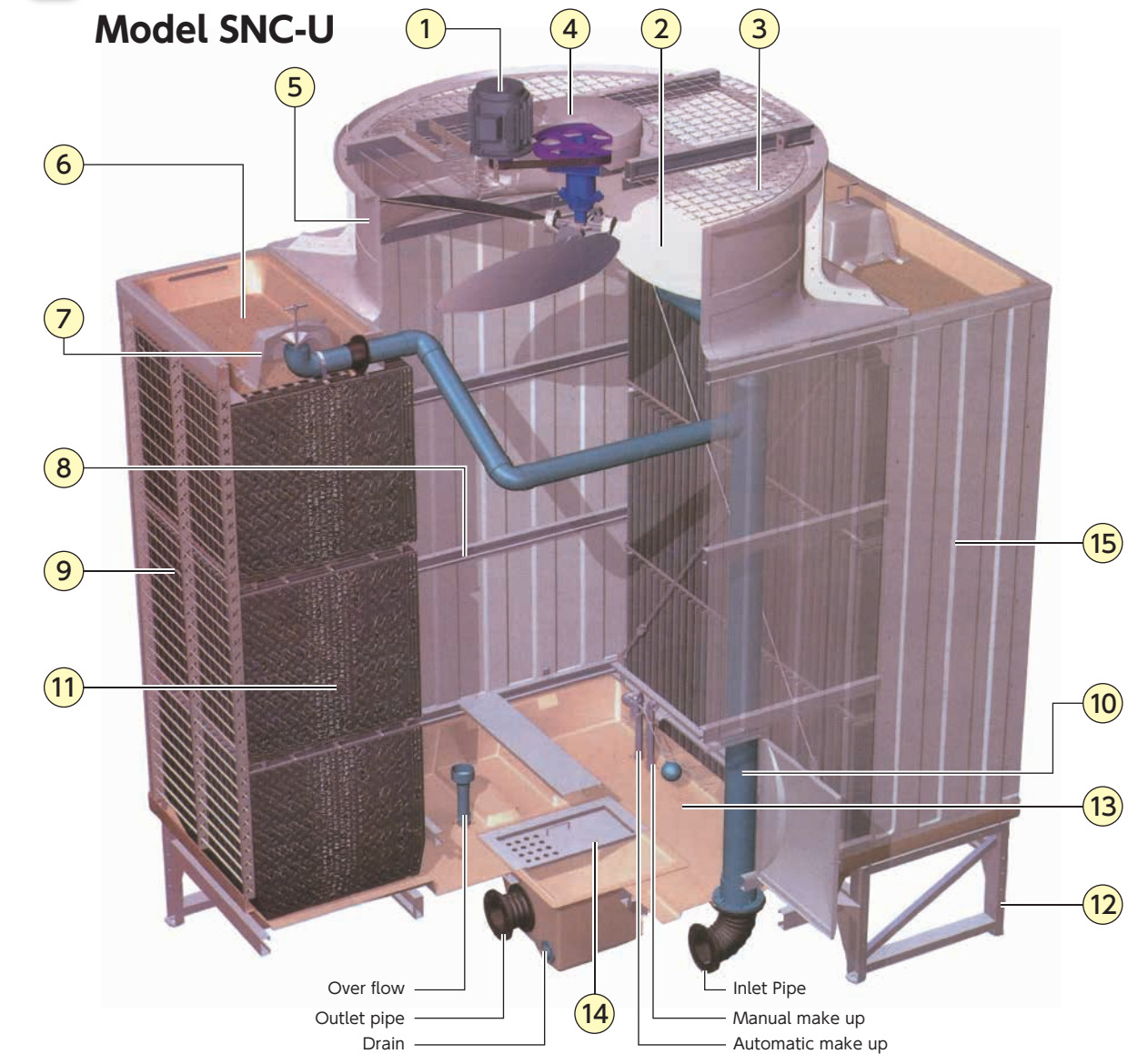

No.	Parts Name	Material	Q'ty	Remarks
1	Motor		1Pc	Total Enclosed Outdoor
2	Fan	Alum. Alloy Cast	1Set	
3	Fan Guard	H.D.G. Steel	1Set	Hot Dip Galvanized
4	Belt Cover	F.R.P.	1Set	
5	Fan Casing	F.R.P.	1Set	
6	Upper Water Basin	F.R.P.	2Pc	
7	Sprinkler Cover	F.R.P.	2Pc	With Simple Water Level Adjustment Valve
8	Frame Works	H.D.G. Steel	1Set	Hot Dip Galvanized

No.	Parts Name	Material	Q'ty	Remarks
9	Louver	P.V.C.	2Side	
10	Inlet Piping	P.V.C.	1Set	
11	Fill	P.V.C.	1Set	
12	Lower Frame	H.D.G. Steel	1Set	Hot Dip Galvanized
13	Lower Water Basin	F.R.P.	1Set	Inclined
14	Strainer	H.D.G. Steel	1Pc	Hot Dip Galvanized
15	Casing Panel	P.V.C.	2Side	

Standard color : Grey (mancel N-7)

Option

FRP Duct

Avoid air short circuiting
Reduce noise level

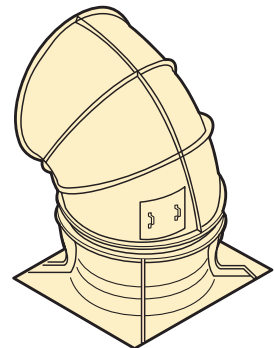

90° Elbow Duct

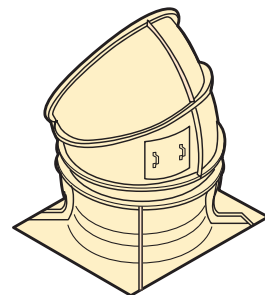

60° Elbow Duct

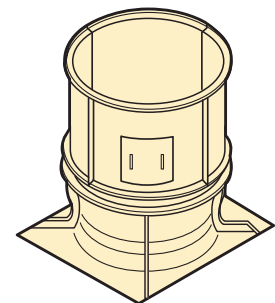

Straight Duct (1mH, 2mH)

Upper Water Basin Cover (FRP)

Protect from invasion of dust into the upper basin
Interrupt sunlight which is causing algae growth
Possible to walk on the cover

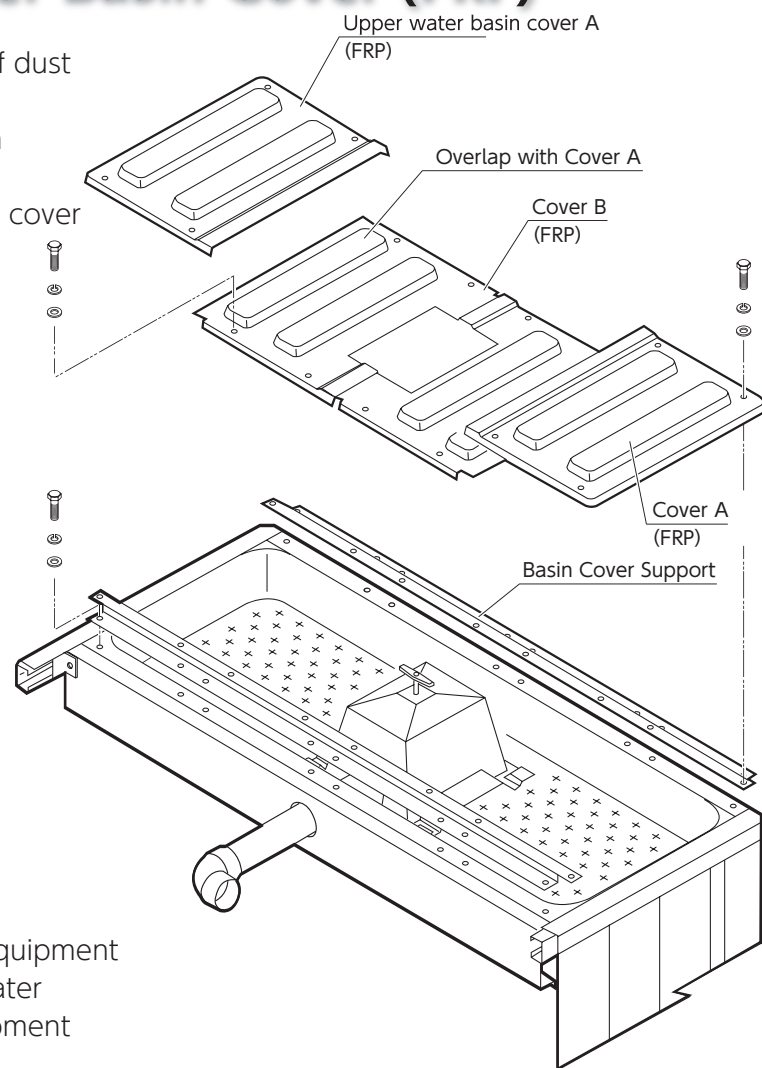

Other Option Item
Partition
High Temp Fill
Vibration Absorption Equipment
Anti-Freeze Electric Heater
Water Treatment Equipment

Handrail, Cage Ladder, Platform and Step

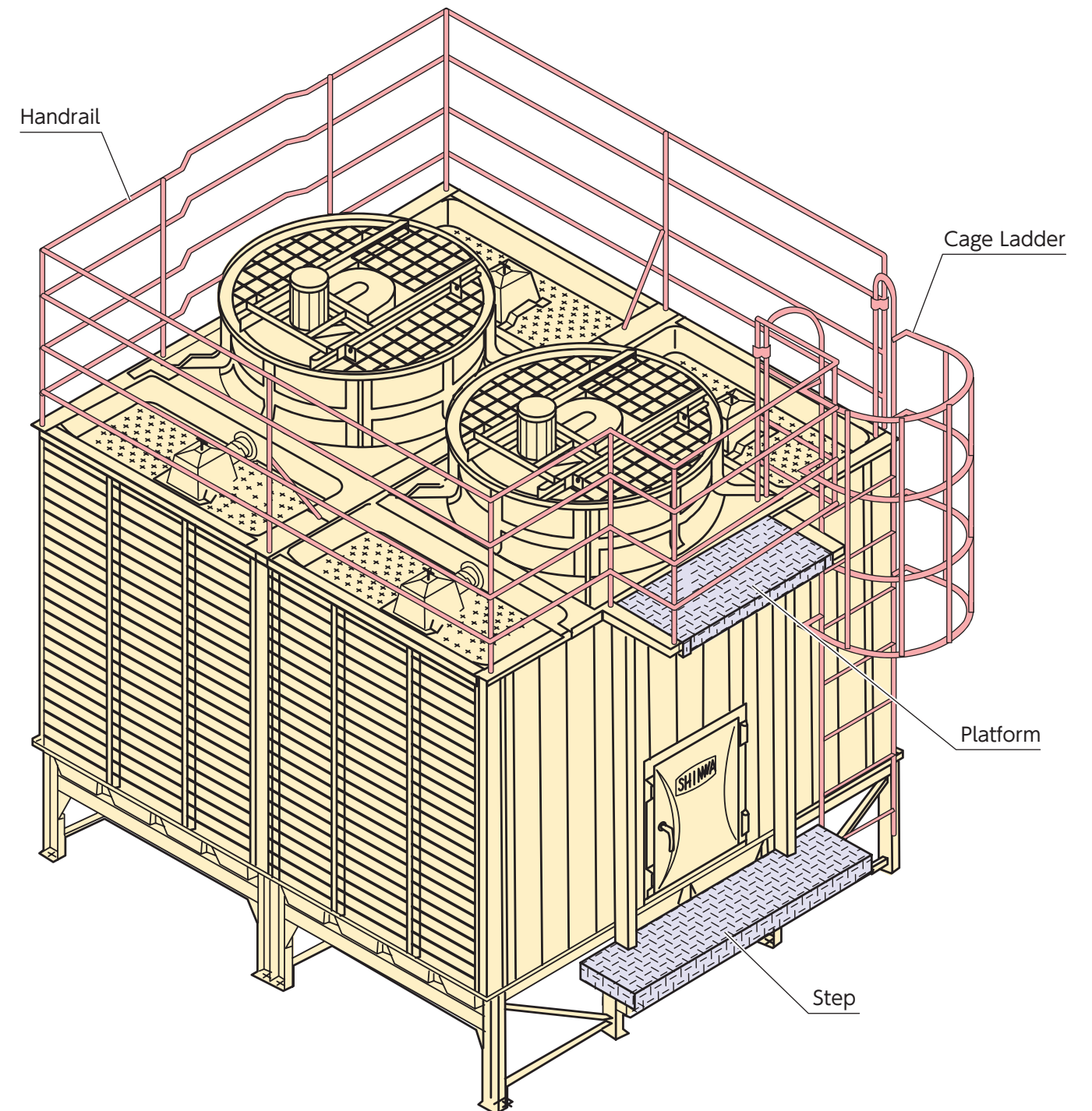

We give answers to any of your request with our variety of selection



Cross Flow Type (Model SLC)



Closed circuit Type (Model MXC)

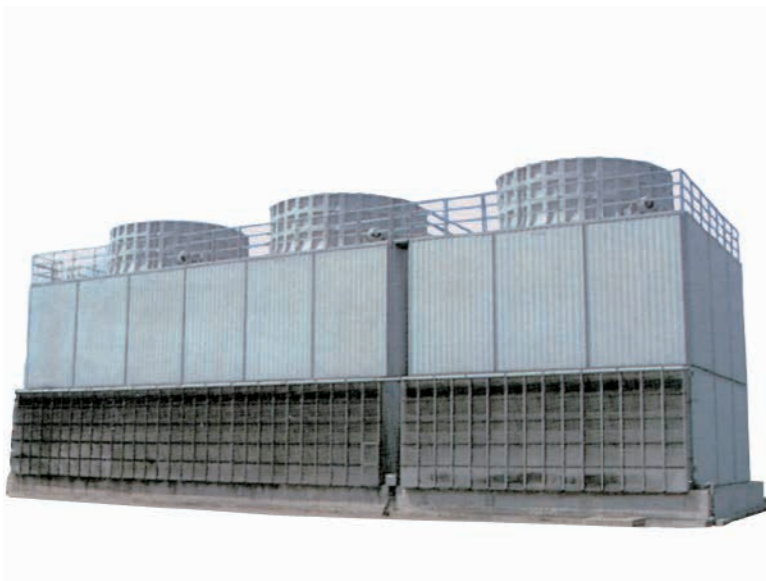

Counter Flow Type (Model SCC)



Counter Flow Type (Model SBC)

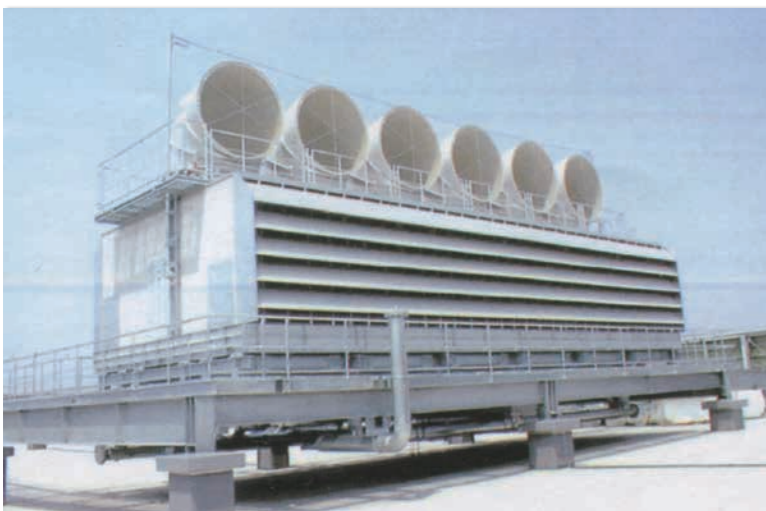

Cross Flow Type (Model SNC-R)



Cautions for Installation Works

1. Scope of Works (Standard)

The following works at site shall be out of our scope.

- ① Lift up and carry works
- ② Foundation works (incl. installation of anchor bolts, mortar filled works and installation of steel frame stand.)
- ③ Piping works
- ④ Electric (wiring) works

2. Selection of installation place

Select an installation place based on the Building Standards Act or Regulations.

- ① A place with good ventilation where discharged air from cooling tower will not recirculate.
- ② Avoid places with much dust, dirt or smoke and places near heat sources.

- ③ If the walls will be placed around the cooling tower, at least the cooling tower louver height space needed between them. The wall should be lower than the cooling tower.
- ④ Select a place where the noise is not magnified by echoes. Avoid the vicinity of windows of neighboring houses as much as possible.
- ⑤ Avoid a place where has no fresh air intake for air conditioning.

3. Other Cautions

- ① Foundation level should be horizontally.
- ② Foundation bolts should be furnished before cooling towers deliver to the site.

Operational Cautions

1. Operation

- ① The specified water flow must be maintained to obtain and hold the rated capacity.
- ② As V-Belt may stretch at the early stage of operation, make the first check the day after the operation commissioning to adjust, if any. Thereafter, the periodic checks and adjustment are necessary.
- ③ During the operation always watch for the vibration, noise, the electric current and the cooling water temperature. Vibration and noise primarily originates from the moving parts, such as belt speed reducer, motor and fan. Do not overlook even slightest abnormalities.

2. Maintenance

- ① Regularly drain water and clean the lower water basin and strainer.
- ② Water quality control are recommended to prevent poor water quality, scale and algae growth.
- ③ Consumption parts such as V-belts and bearings are required to replace periodically (estimated timing for exchanging a V-belt is roughly 7000-8000 hours).



Precautions for Safety

Cooling towers described in this catalogue are of our standard specifications.

■ Before Use

- Before use, read the "Instruction Manual" carefully and use the towers correctly.

■ Before Installation

- Request installation from the distributor or professional agency.
- Improper installation work may cause toppling, water leakage, electric shocks or fire which will endanger operations.
- Make sure to use extra-cost options such as an electric heater designated by us.
- Space is required for maintenance work around the machine. Lack of space may obstruct safety work and cause injuries.

■ Locations for Use

- Do not install in places where combustible gases leak or flammables exist.
Fire may occur in places where flammable gases are generated, flow in or are retained, and carbon fibers are floated.

■ Maintenance and Inspection

- Periodic maintenance and inspection is required other than inspections for daily operation. Improper maintenance and inspection may cause a fire, electric shocks and burns.
As maintenance and inspection requires special skills, consult manufacturer or distributor.

※Notice for Water Quality Control

If the circulating water is left as it is, slime deposits in the water bath and piping will develop. The slime is formed from many kinds of algae and fungi, particularly; metabolic products from algae sometimes help fungi grow.

Disease-causing bacteria among bacteria may also exist, therefore, please be advised to clean or control the water quality at least once a month to prevent algae from forming.

● your contact



EBARA REFRIGERATION EQUIPMENT & SYSTEMS CO., LTD.
SHINWA COOLING TOWER BUSINESS DIVISION

Specification listed in this brochure are subject to change without notice due to technical improvement on our products.

The Products described herein fall under "the goods listed in row 16 of the appended table 1 of the Export Trade Control Order of Japan", so in cases of export of such Products, you need to confirm "use" and "purchaser and/or end-user" and, as case may be, obtain the approval of the Minister of Economy, Trade and Industry. (Please confirm these conditions on your own.)

Please contact local agents for more information.