



EBARA

PROCESS PUMP

Single Stage, End Suction, Foot Support

CS1150EQ

Model

IFW

ISO 2858

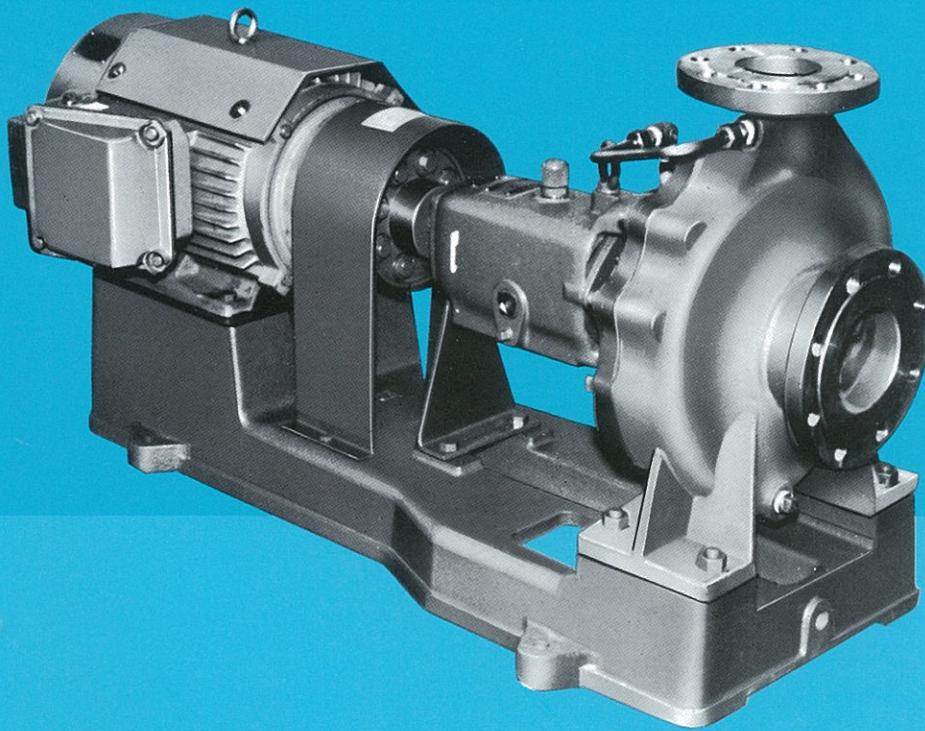

PROCESS PUMP

Single Stage, End Suction, Foot Support

Model

IFW

ISO 2858

EBE

EBARA PROCESS PUMPS MODEL IFW of single stage, end suction, foot supported, horizontal type have been widely used in the chemical industry, petroleum refineries, the petrochemical industry and other industries

for many years. Many improvements have been recently made on this pump to enhance its performance. "The money saver" Our modern mass production facilities enable us to pass the cost-savings on to you. Unique

design of this high performance pump features stainless steel, cast steel casing or cast iron for superior and extended low-cost operation.

Applications

- Chemical Industry
- Petroleum Refineries
- The Petrochemical Industry
- Other Industries

Ratings

Capacities	To 24 m ³ /min (3700 USGPM)
Heads	To 140 m (470 ft)
Discharge pressures	To gauge pressure 1.57MPa(230PSI) {16kgf/cm ² }
Max. allowable suction pressures	To gauge pressure 0.88MPa(130PSI) {9kgf/cm ² }
Hydrostatic test pressures	To gauge pressure 2.3MPa(340PSI) {24kgf/cm ² }
Speed	50 Hz 1450 or 2950 min ⁻¹ 60 Hz 1750 or 3550 min ⁻¹
Max. allowable speed	To 3600 min ⁻¹
Rotation	Clockwise viewed from inboard side
Impeller type	Enclosed
Temperatures	Stainless steel: -50°C to 200°C (-58°F to 392°F) Cast steel: -5°C to 200°C (-23°F to 392°F) Cast iron: -15°C to 150°C (-5°F to 300°F)
Flange rating	JIS10KRF/ANSI 150 RF (Stainless steel, Cast steel) JIS10KFF/ANSI 125 FF (Cast Iron)
Nozzles	End-Top
Stuffing box	Suitable for conventional packing & mechanical seal

Features

- Foot support and heavy duty design.
- Back pull-out casing.
- Full compliance with ISO 2858 specifications.
- All components have been designed for maximum parts interchangeability.
- Flexibility of design handles wide range of liquids.
- All sizes stocked for fast shipment.
- Low NPSH performance.

Wide-Range for Best Choice!!

Availability in modules provides complete interchangeability of components between different types and permits pump selections best suited for the given specifications.

	Bearing casting	Shaft	Gland cover	Impeller	Casting	Pump model designation
Bearing Group I						40×25-1312
						40×25-1612
						40×25-2013
Bearing Group II						50×40-1323
						50×40-1623
						50×40-2013
						50×40-2524
						80×50-1313
						80×50-1623
						80×50-2023
Bearing Group III						80×50-3214
						80×50-3224
						100×80-1314
						100×80-1614
						100×80-2024
						100×80-2524
						100×80-3215
						150×100-1614X
						150×100-2015X
						150×100-2525X
Bearing Group IV						150×100-2515XA
						150×100-3225X
						150×100-3215XA
						150×100-4015X
						150-2015Y
						150-2515Y
Bearing Group V for 2P only 150×100-2515XA 150×100-3215XA						150×100-3225Y
						150×100-4025Y
						150×100-5016Y
						200-2015
Bearing Group VI						200-2515
						200×150-3216
						200×150-4026
						200×150-5028
Bearing Group VII						250-2516
						250×200-3216
						250×200-4016
						250×200-5028

Selection Chart



50Hz

2pole [Synchronous speed : 3000min⁻¹]

HIFW-52S5 040820

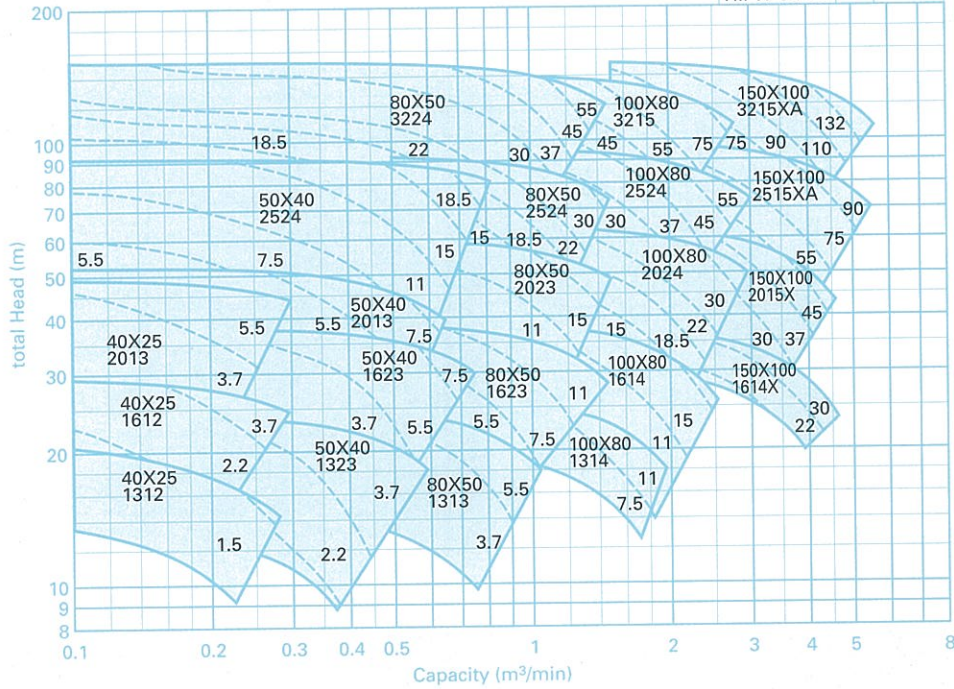

4pole [Synchronous speed : 1500min⁻¹]

HIFW-54S5 040820

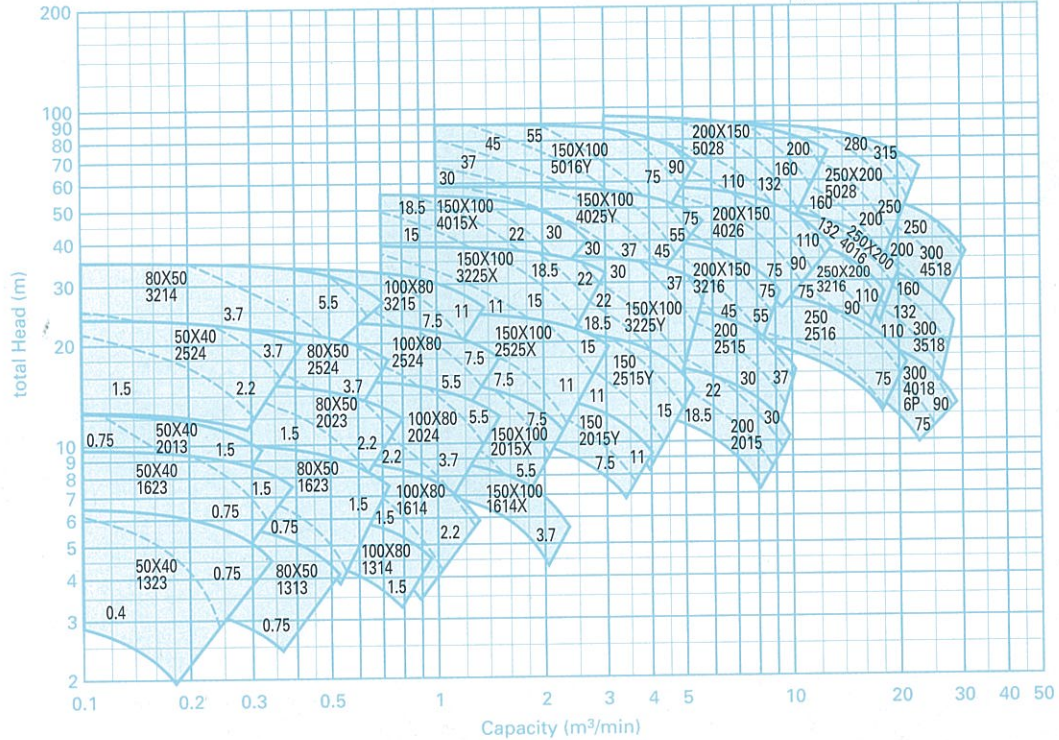

Selection Chart



60Hz

2pole [Synchronous speed : 3600min⁻¹]

HIFW-62S5 040820

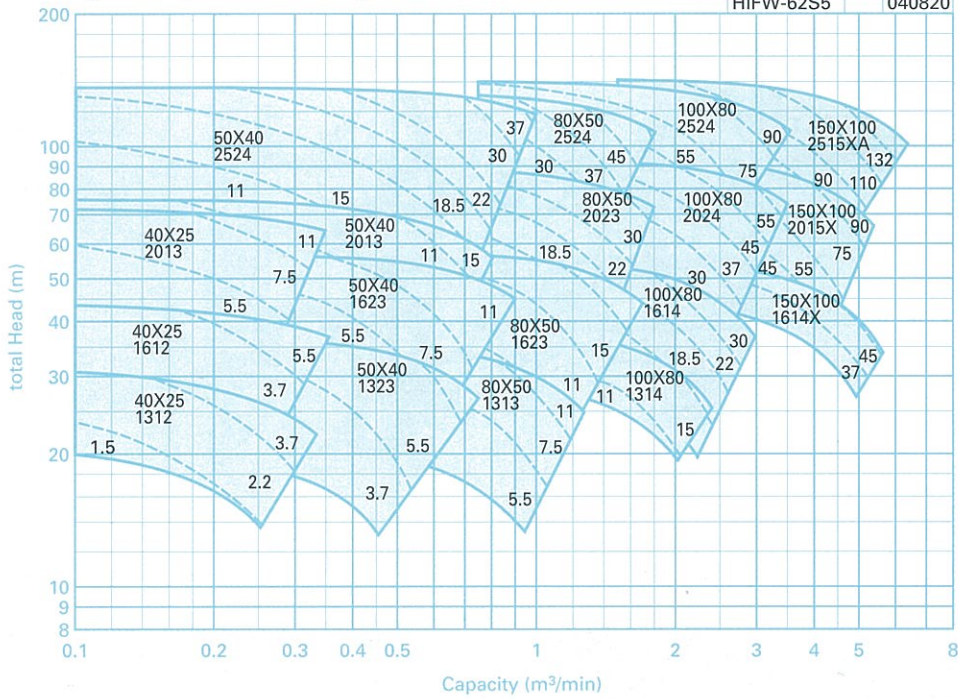

4pole [Synchronous speed : 1800min⁻¹]

HIFW-64S5 040820

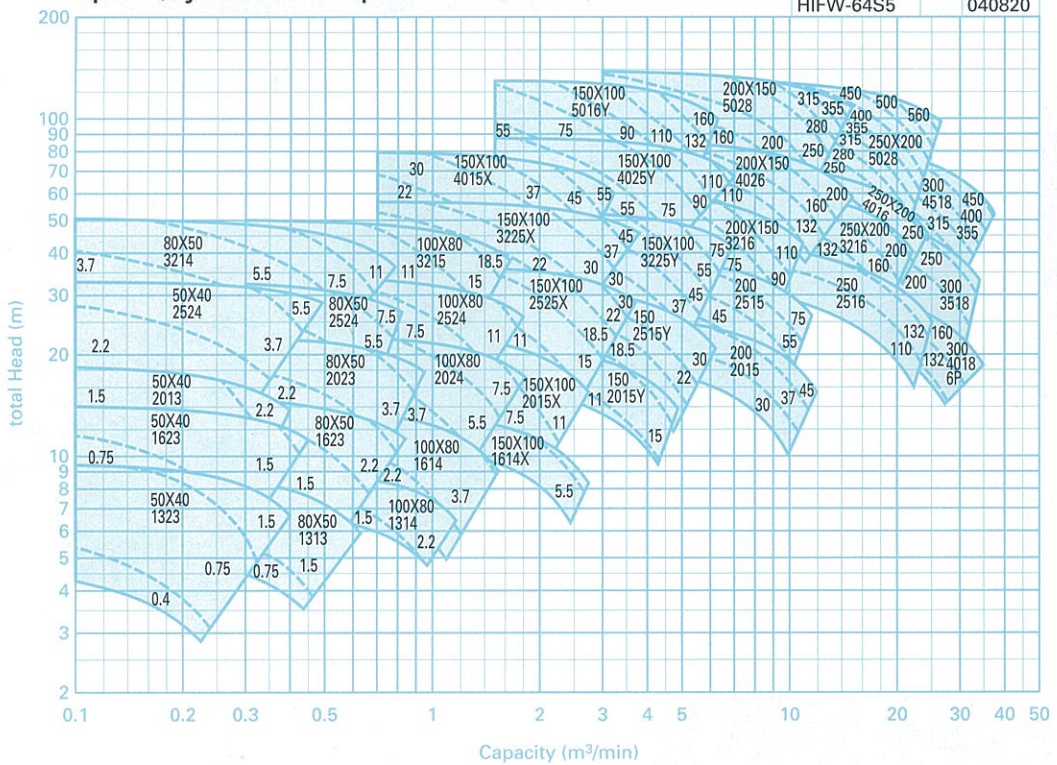

Construction



Sectional Drawing of Standard Type (Cast Iron)

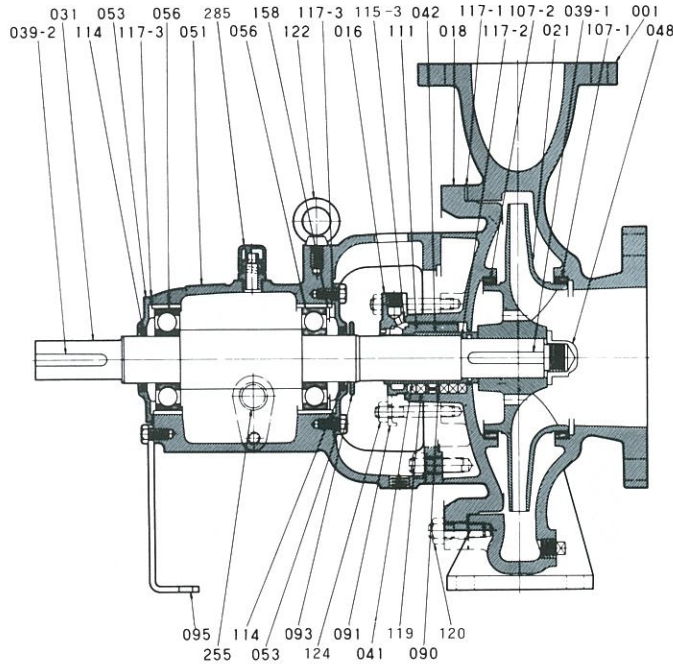

Part List

No.	Name of part	Material		Quantity
		Cast iron	Ductile cast iron	
001	Casing	FC250	FCD	1
016	Mechanical seal cover	SUS304	SUS304	1
018	Gland cover	FC250	FCD	1
021	Impeller	FC200	FC200	1
031	Shaft	S35C	S35C	1
039-1	Impeller key	S50C	S50C	1
039-2	Coupling key	S50C	S50C	1
041	Packing sleeve	SUS403	SUS403	1
042	Mechanical seal sleeve	SUS316	SUS316	1
048	Impeller nut	S30C	S30C	1
051	Bearing casing	FC200	FC200	1
053	Bearing cover	FC200	FC200	2
056	Ball bearing	—	—	2
066	Cooling cover	FC200	FC200	1
090	Lantern ring	SUS304	SUS304	1
091	Packing gland	FC150	FC150	1
093	Flinger	SUS304	SUS304	1
095	Stay	SS400	SS400	1
107-1	Liner ring	FCD400	FCD400	1
107-2	Liner ring	FCD400	FCD400	1
111	Mechanical seal	—	—	1
114	Oil seal	SPHC/NBR	SPHC/NBR	2
115-3	O-ring for mechanical seal cover	Teflon	Teflon	1
117-1	Gasket for casing	V#6500	V#6500	1
117-2	Gasket for shaft sleeve	V#6500AC	V#6500AC	1
117-3	Gasket for bearing cover	OIL SHEET	OIL SHEET	1
117-4	Gasket for cooling cover	NBR	NBR	2
119	Gland packing	P#6501L	P#6501L	5
120	Casing bolt	SS400/SUS403	SS400/SUS403	1 set
122	Hook bolt	S20C	S20C	1
124	Gland bolt	SUS403	SUS403	2,4
158	Wave washer	SK5	SK5	1
255	Oil level gauge	Synthetic rubber/Glass	Synthetic rubber/Glass	1
285	Air Breather	Polycarbonate	Polycarbonate	1

- (Note) 1. Combinations of parts in other materials than listed are also available upon request.
 2. Packing/gasket material letters is as following.
 P: Nippon Pillar made.
 V: Nippon Valqua made.

Bearing Casing with Cooling Jacket

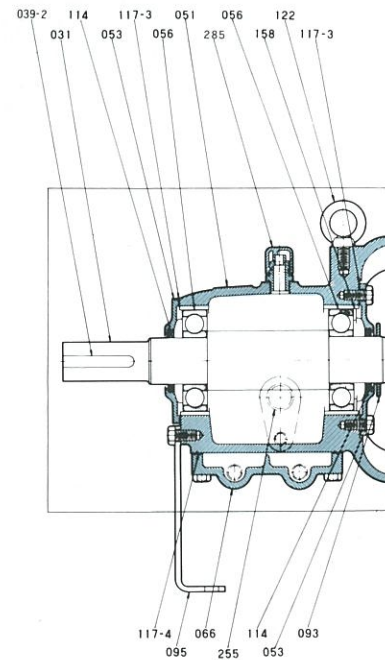

Construction

Bco
Model-IFW

Sectional Drawing
of Standard Type
(Stainless steel, Cast steel)

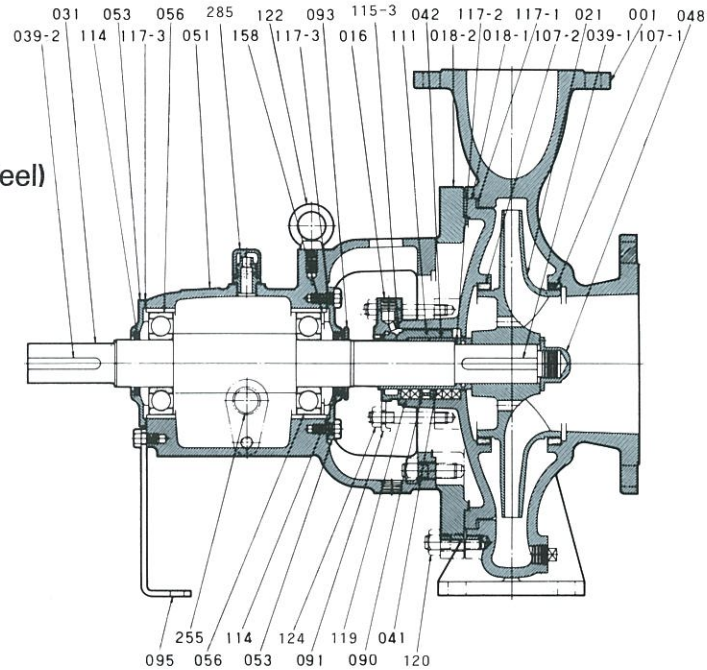

Stuffing Box with Cooling Jacket

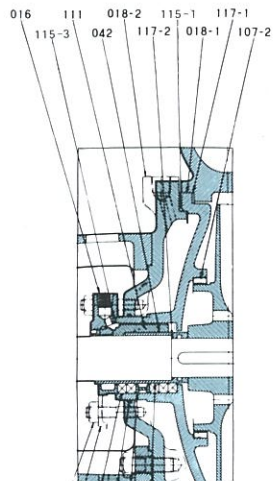

Part List

No.	Name of part	Material			Quantity
		Stainless steel	Cast steel		
001	Casing	SCS14	SCS13	SC480	1
016	Mechanical seal cover	SUS316	SUS304	SUS304	1
018-1	Gland cover (I)	SCS14	SCS13	SC480	1
018-2	Gland cover (II)	FCD400	FCD400	FCD400	1
021	Impeller	SCS14	SCS13	FC200	1
031	Shaft	SUS316	SUS304	S35C	1
039-1	Impeller key	SUS316	SUS316	S50C	1
039-2	Coupling key	S50C	S50C	S50C	1
041	Packing sleeve	SUS316	SUS304	SUS420J1	1
042	Mechanical seal sleeve	SUS316	SUS304	SUS403	1
048	Impeller nut	SUS316	SUS304	S30C	1
051	Bearing casing	FC200	FC200	FC200	1
053	Bearing cover	FC200	FC200	FC200	2
056	Ball bearing	—	—	—	2
066	Water-cooling cover	FC200	FC200	FC200	1
090	Lantern ring	SUS316	SUS304	SUS304	1
091	Packing gland	SCS14	SCS13	FC150	1
093	Flinger	SUS316	SUS304	SUS304	1
095	Stay	SS400	SS400	SS400	1
107-1	Liner ring	SUS316	SUS304	FCD400	1
107-2	Liner ring	SUS316	SUS304	FCD400	1

Shaft Sealing System



	A	B	C
1	<p>1A Balanced seal (Standard type)</p>	<p>1B Balanced seal (Quench type)</p>	<p>1C Double seal (Open air-side balanced type)</p>
2	<p>2A Unbalanced seal (Standard type)</p>	<p>2B Unbalanced seal (Quench type)</p>	<p>2C Double seal (Open air-side unbalanced type)</p>
3	<p>3A Metal bellows (Standard type)</p>	<p>3B Mono Coil Seal</p>	<p>3C Outside seal</p>
4	<p>4A Gland packing (Standard type)</p>	<p>4B Gland packing (Quench type)</p>	<p>1. Dimensions of the shaft sealing packing box are subject to ISO-3069. Mechanical seal is standardized to DIN 24690 in type and dimensions.</p> <p>2. Other shaft sealing systems are available to meet different service requirements.</p>

Dimensions

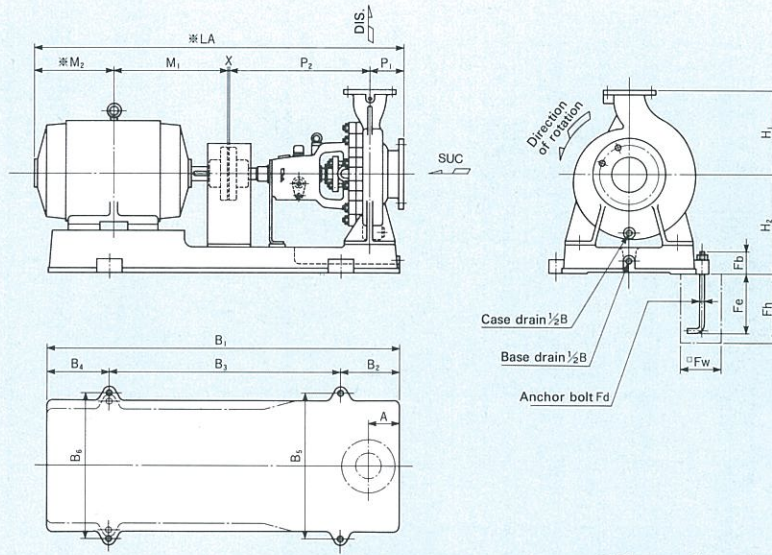

● Flange dimensions (JIS 10K, Regular flanges)
for cast iron, cast steel and stainless steel pumps.

Unit: mm

Pump Model	Motor		Pump				Common base								Motor		*LA	X	Anchor bolt					Wt (kg)	Coupling	
	Frame	kW	P ₁	P ₂	H ₁	H ₂	A	B ₁	B ₂	B ₃	B ₄	B ₅	B ₆	M ₁	*M ₂	F _d			F _b	F _e	F _h	F _w	CLA		CLAB	
40×25 IFWM	80	0.75	80	385	160	212	60	725	115	480	130	290	250	140	133	741	3	M12	55	195	250	110	64	112	4-10	
	1312	90L	1.5/2.2	80	385	160	222	60	725	115	480	130	290	250	168.5	158.5	795	3	M12	55	195	250	110	64	112	4-10
	112M	3.7	80	385	160	212	60	765	130	540	95	320	320	200	183	851	3	M12	55	195	250	110	69	112	4-10	
	1612	132S	5.5/7.5	80	385	160	240	60	805	130	540	135	350	350	239	210	917	3	M12	55	195	250	110	71	140	6-14
40×25 IFWM	112M	3.7	80	385	180	240	60	765	130	540	95	320	320	200	183	851	3	M12	55	195	250	110	83	112	4-10	
	132S	5.5/7.5	80	385	180	240	60	805	130	540	135	350	350	239	210	917	3	M12	55	195	250	110	81	140	6-14	
	160M	11	80	385	180	255	60	970	170	660	140	400	400	323	280	1071	3	M12	55	195	250	110	101	140	6-14	
50×40 IFWM	71	0.4	80	385	160	212	60	725	115	480	130	290	250	120	121	709	3	M12	55	195	250	110	70	112	4-10	
	1323	80	0.75	80	385	160	212	60	725	115	480	130	290	250	140	133	741	3	M12	55	195	250	110	69	112	4-10
50×40 IFWM	90L	1.5/2.2	80	385	160	222	60	725	115	480	130	290	250	168.5	158.5	795	3	M12	55	195	250	110	69	112	4-10	
	1623	112M	3.7	80	385	160	212	60	765	130	540	95	320	320	200	183	851	3	M12	55	195	250	110	74	112	4-10
	132S	5.5/7.5	80	385	160	240	60	805	130	540	135	350	350	239	210	917	3	M12	55	195	250	110	76	140	6-14	
	160M	11	80	385	160	255	60	970	170	660	140	400	400	323	280	1071	3	M12	55	195	250	110	95	140	6-14	
50×40 IFWM	80	0.75	100	385	180	240	60	725	115	480	130	320	250	140	133	761	3	M12	55	195	250	110	82	112	4-10	
	2013	90L	1.5	100	385	180	250	60	725	115	480	130	320	250	168.5	158.5	815	3	M12	55	195	250	110	83	112	4-10
		100L	2.2	100	385	180	240	60	765	130	540	95	320	320	193	173	854	3	M12	55	195	250	110	85	112	4-10
		132S	5.5/7.5	100	385	180	240	60	805	130	540	135	350	350	239	210	937	3	M12	55	195	250	110	86	140	6-14
		160M	11	100	385	180	255	60	970	170	660	140	400	400	323	280	1091	3	M12	55	195	250	110	103	140	6-14
50×40 IFWM	90L	1.5	100	500	225	275	75	900	150	600	150	400	320	168.5	158.5	930	3	M12	55	195	250	110	115	140	6-14	
	2524	100L	2.2	100	500	225	275	75	900	150	600	150	400	320	193	173	969	3	M12	55	195	250	110	114	140	6-14
		112M	3.7	100	500	225	287	75	900	150	600	150	400	320	200	183	986	3	M12	55	195	250	110	115	140	6-14
		132S	5.5/7.5	100	500	225	275	75	995	170	660	165	400	400	239	210	1052	3	M12	55	195	250	110	123	140	6-14
		160M	11	100	500	225	275	75	1120	190	740	190	440	440	323	280	1206	3	M12	55	195	250	110	136	140	6-14
		160L	18.5	100	500	225	275	75	1120	190	740	190	440	440	345	302	1250	3	M12	55	195	250	110	136	160	8-14
		180M	22	100	500	225	275	75	1120	190	740	190	440	440	351.5	325	1279.5	3	M12	55	195	250	110	133	160	8-14
		180L	30	100	500	225	275	75	1260	205	840	215	490	490	370.5	344	1317.5	3	M12	55	195	250	110	153	180	8-14
80×50 IFWM	71	0.4	100	385	180	240	60	725	115	480	130	320	250	120	121	729	3	M12	55	195	250	110	77	112	4-10	
	1313	80	0.75	100	385	180	240	60	725	115	480	130	320	250	140	133	761	3	M12	55	195	250	110	77	112	4-10
80×50 IFWM	90L	1.5	100	385	180	250	60	725	115	480	130	320	250	168.5	158.5	815	3	M12	55	195	250	110	78	112	4-10	
	1623	100L	2.2	100	385	180	240	60	765	130	540	95	320	320	193	173	854	3	M12	55	195	250	110	80	112	4-10
		112M	3.7	100	385	180	240	60	765	130	540	95	320	320	200	183	871	3	M12	55	195	250	110	80	112	4-10
		132S	5.5/7.5	100	385	180	240	60	805	130	540	135	350	350	239	210	937	3	M12	55	195	250	110	81	140	6-14
		160M	11	100	385	180	255	60	970	170	660	140	400	400	323	280	1091	3	M12	55	195	250	110	98	140	6-14
		160L	18.5	100	385	180	255	60	970	170	660	140	400	400	345	302	1135	3	M12	55	195	250	110	103	160	8-14

- Notes: 1. Motor output classification numbers shown are for ordinary E class totally-enclosed, fan-cooled low-voltage 3-phase squirrel-cage induction motors under JEM-1400-1983
 2. M₂ and LA dimensions marked with an asterisk vary to a certain extent, depending on motor manufacturers.
 3. Dimensions are subject to change without notice.
 4. In two motor ratings(kW) with slash mark, left side is the rating of four poles, right side is the rating of two poles.

Dimensions

Beo
Model-IFW

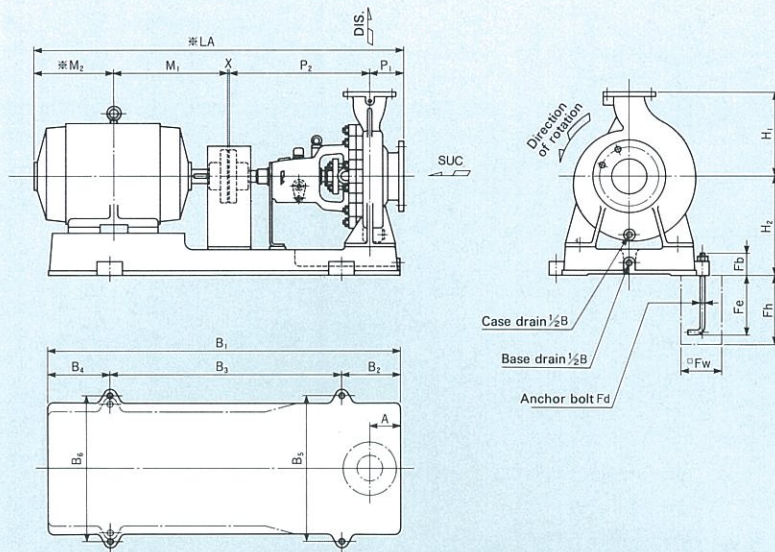

● Flange dimensions (JIS 10K, Regular flanges) for cast iron, cast steel and stainless steel pumps.

Unit: mm

Pump Model	Motor Frame	Motor kW	Pump			Common base								Motor M ₁	*M ₂	*LA	X	Anchor bolt				F _w	W _t (Mass) kg	Coupling	
			P ₁	P ₂	H ₁	H ₂	A	B ₁	B ₂	B ₃	B ₄	B ₅	B ₆					F _d	F _b	F _e	F _h			CLA	CLAB
80×50 IFWM 2023	90L	1.5	100	385	200	250	60	725	115	480	130	320	250	168.5	158.5	815	3	M12	55	195	250	110	88	112	4-10
	100L	2.2	100	385	200	240	60	765	130	540	95	320	320	193	173	854	3	M12	55	195	250	110	90	112	4-10
	112M	3.7	100	385	200	240	60	765	130	540	95	320	320	200	183	871	3	M12	55	195	250	110	90	125	4-14
	132S	5.5/7.5	100	385	200	240	60	805	130	540	135	350	350	239	210	937	3	M12	55	195	250	110	89	140MB	6-14
	160M	11/15	100	385	200	255	60	970	170	660	140	400	400	323	280	1091	3	M12	55	195	250	110	108	140	6-14
	160L	18.5	100	385	200	255	60	970	170	660	140	400	400	345	302	1135	3	M12	55	195	250	110	113	160	8-14
	180M	22	100	385	200	275	60	1015	170	660	185	320	440	351.5	325	1164.5	3	M12	55	195	250	110	111	160	8-14
	180L	30	100	385	200	275	60	1015	170	660	185	320	440	370.5	344	1202.5	3	M12	55	195	250	110	111	180	8-14
80×50 IFWM 2524	90L	1.5	125	500	225	275	75	900	150	600	150	400	320	168.5	158.5	955	3	M12	55	195	250	110	122	140	6-14
	100L	2.2	125	500	225	275	75	900	150	600	150	400	320	193	173	994	3	M12	55	195	250	110	122	140	6-14
	112M	3.7	125	500	225	287	75	900	150	600	150	400	320	200	183	1011	3	M12	55	195	250	110	122	140	6-14
	132S	5.5	125	500	225	275	75	995	170	660	165	400	400	239	210	1077	3	M12	55	195	250	110	131	140	6-14
	132M	7.5	125	500	225	275	75	995	170	660	165	400	400	258	229	1115	3	M12	55	195	250	110	132	160	8-14
	160M	11/15	125	500	225	275	75	1120	190	740	190	440	440	323	280	1231	3	M12	55	195	250	110	144	140	6-14
	160L	18.5	125	500	225	275	75	1120	190	740	190	440	440	345	302	1275	3	M12	55	195	250	110	144	160	8-14
	180M	22	125	500	225	275	75	1120	190	740	190	440	440	351.5	325	1304.5	3	M12	55	195	250	110	141	160	8-14
	180L	30	125	500	225	275	75	1260	205	840	215	490	490	370.5	344	1342.5	3	M12	55	195	250	110	161	180	8-14
	200L	37	125	500	225	295	75	1245	205	840	200	400	490	395.5	377	1400.5	3	M12	55	195	250	110	158	180	8-14
80×50 IFWM 3214 (Only for 4P) 3224 (Only for 2P)	100L	2.2	125	500	280	320	75	905	150	600	155	400	320	193	173	994	3	M12	55	195	250	110	160	140	6-14
	112M	3.7	125	500	280	332	75	905	150	600	155	400	320	200	183	1011	3	M12	55	195	250	110	161	140	6-14
	132S	5.5	125	500	280	320	75	990	170	660	160	440	350	239	210	1077	3	M12	55	195	250	110	162	140	6-14
	132M	7.5	125	500	280	320	75	990	170	660	160	440	350	258	229	1115	3	M12	55	195	250	110	162	160	8-14
	160M	11/15	125	500	280	320	75	1120	190	740	190	440	440	323	280	1231	3	M12	55	195	250	110	175	160	8-14
	160L	18.5	125	500	280	320	75	1120	190	740	190	440	440	345	302	1275	3	M12	55	195	250	110	175	160	8-14
	180M	22	125	500	280	340	75	1120	190	740	190	440	440	351.5	325	1304.5	3	M12	55	195	250	110	177	160	8-14
	180L	30	125	500	280	320	75	1265	205	840	220	490	490	370.5	344	1342.5	3	M12	55	195	250	110	202	180	8-14
200L	37	125	500	280	320	75	1265	205	840	220	490	490	395.5	377	1400.5	3	M12	55	195	250	110	192	180	8-14	
100×80 IFWM 1314 100×80 IFWM 1614	90L	1.5	100	500	200	240	75	880	150	600	130	350	290	168.5	158.5	930	3	M12	55	195	250	110	100	140	6-14
	100L	2.2	100	500	200	240	75	880	150	600	130	350	290	193	173	969	3	M12	55	195	250	110	99	140	6-14
	112M	3.7	100	500	200	240	75	900	150	600	150	350	350	200	183	986	3	M12	55	195	250	110	103	140	6-14
	132S	5.5/7.5	100	500	200	255	75	970	170	660	140	400	400	239	210	1052	3	M12	55	195	250	110	160	140	6-14
	160M	11/15	100	500	200	255	75	1120	190	740	190	440	440	323	280	1206	3	M12	55	195	250	110	121	140	6-14
	160L	18.5	100	500	200	255	75	1120	190	740	190	440	440	345	302	1250	3	M12	55	195	250	110	121	160	8-14
	180M	22	100	500	200	275	75	1120	190	740	190	440	440	351.5	325	1279.5	3	M12	55	195	250	110	125	160	8-14
	180L	30	100	500	200	275	75	1245	205	840	200	400	490	370.5	344	1317.5	3	M12	55	195	250	110	143	180	8-14

- Notes: 1. Motor output classification numbers shown are for ordinary E class totally-enclosed, fan-cooled low-voltage 3-phase squirrel-cage induction motors under JEM-1400-1983
 2. M₂ and LA dimensions marked with an asterisk vary to a certain extent, depending on motor manufacturers.
 3. Dimensions are subject to change without notice.
 4. In two motor ratings(kW) with slash mark, left side is the rating of four poles, right side is the rating of two poles.

Dimensions

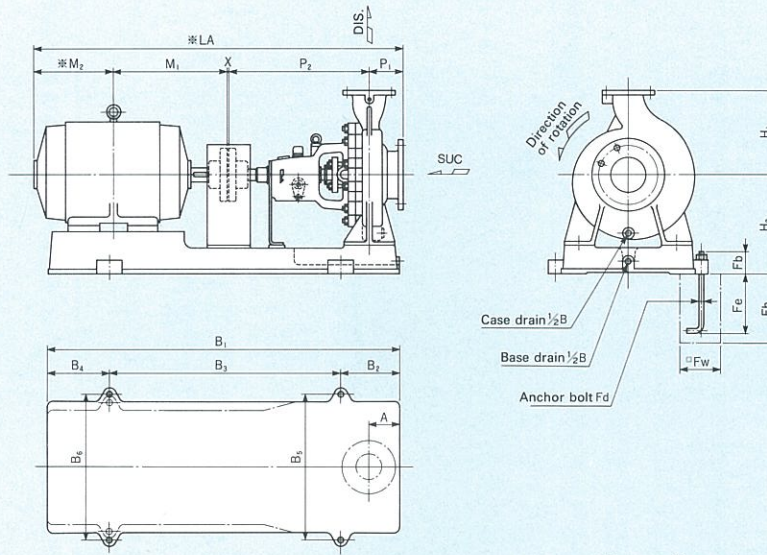

● Flange dimensions (JIS 10K, Regular flanges) for cast iron, cast steel and stainless steel pumps.

Unit: mm

Pump Model	Motor		Pump						Common base						Motor		* LA	X	Anchor bolt						Wt (kg)	Coupling	
	Frame	kW	P ₁	P ₂	H ₁	H ₂	A	B ₁	B ₂	B ₃	B ₄	B ₅	B ₆	M ₁	*M ₂	F _d			F _b	F _e	F _h	F _w	GLA	GLAB			
150×100 IFWM 4015X	160M	11	140	530	355	395	110	1265	205	840	220	600	400	323	280	1276	3	M16	70	245	315	130	282	160	8-14		
	160L	15	140	530	355	395	110	1265	205	840	220	600	400	345	302	1320	3	M16	70	245	315	130	282	160	8-14		
	180M	$\frac{18}{22}^5$	140	530	355	395	110	1265	205	840	220	600	490	351.5	325	1349.5	3	M16	70	245	315	130	288	180	8-14		
	180L	30	140	530	355	395	110	1265	205	840	220	600	490	370.5	344	1388.5	4	M16	70	245	315	130	293	200	8-20		
	200L	$\frac{37}{45}$	140	530	355	415	110	1265	205	840	220	600	490	425.5	377	1476.5	4	M16	70	245	315	130	303	224	8-20		
225S	55	140	530	355	395	110	1425	230	940	255	600	600	432	388	1494	4	M16	70	245	315	130	335	224MB	8-20			
150 IFWM 2015Y	132M	7.5	140	530	355	345	90	1025	170	660	195	490	350	258	229	1160	3	M12	55	195	250	110	199	160	8-14		
	160M	11	140	530	355	373	90	1120	190	740	190	490	400	323	280	1276	3	M12	55	195	250	110	210	160	8-14		
150 IFWM 2515Y	160L	15	140	530	355	345	90	1240	205	840	195	490	490	345	302	1320	3	M12	55	195	250	110	220	160	8-14		
	180M	$\frac{18}{22}^5$	140	530	355	365	90	1240	205	840	195	490	490	351.5	325	1349.5	3	M12	55	195	250	110	223	180	8-14		
	180L	30	140	530	355	365	90	1240	205	840	195	490	490	370.5	344	1388.5	4	M12	55	195	250	110	231	200	8-20		
	200L	37	140	530	355	345	90	1265	205	840	220	490	490	425.5	377	1476.5	4	M12	55	195	250	110	240	224	8-20		
150×100 IFWM 3225Y	160L	15	140	530	355	395	110	1265	205	840	220	600	400	345	302	1320	3	M16	70	245	315	130	277	160	8-14		
	180M	$\frac{18}{22}^5$	140	530	355	395	110	1265	205	840	220	600	490	351.5	325	1349.5	3	M16	70	245	315	130	286	180	8-14		
	180L	30	140	530	355	395	110	1265	205	840	220	600	490	370.5	344	1388.5	4	M16	70	245	315	130	291	200	8-20		
	200L	$\frac{37}{45}$	140	530	355	415	110	1265	205	840	220	600	490	425.5	377	1476.5	4	M16	70	245	315	130	298	224	8-20		
	225S	55	140	530	355	395	110	1425	230	940	255	600	600	432	388	1494	4	M16	70	245	315	130	320	224MB	8-20		
150×100 IFWM 4025Y	180M	$\frac{18}{22}^5$	140	530	400	430	110	1275	205	840	230	600	490	351.5	325	1349.5	3	M16	70	245	315	130	320	180	8-14		
	180L	30	140	530	400	430	110	1275	205	840	230	600	490	370.5	344	1388.5	4	M16	70	245	315	130	325	200	8-20		
	200L	$\frac{37}{45}$	140	530	400	450	110	1275	205	840	230	600	490	425.5	377	1476.5	4	M16	70	245	315	130	330	224	8-20		
	225S	55	140	530	400	430	110	1440	230	940	270	600	600	432	388	1494	4	M16	70	245	315	130	361	224MB	8-20		
	250S	75	140	530	400	430	110	1440	230	940	270	600	600	463.5	501	1638.5	4	M16	70	245	315	130	352	250MB	8-25		
	250M	90	140	530	400	430	110	1440	230	940	270	600	600	482.5	520	1676.5	4	M16	70	245	315	130	352	250MB	8-25		
	280S	110	140	530	400	430	110	1450	230	940	280	670	670	544	579	1797	4	M16	70	245	315	130	356	280MB	8-28		
150×100 IFWM 5016Y	180L	$\frac{30}{45}$	180	670	450	490	110	1405	230	940	235	670	490	370.5	344	1568.5	4	M16	70	245	315	130	473	200	8-20		
	200L	$\frac{37}{45}$	180	670	450	490	110	1405	230	940	235	670	490	425.5	377	1656.5	4	M16	70	245	315	130	493	224	8-20		
	225S	55	180	670	450	490	110	1610	270	1060	280	670	670	432	388	1674	4	M16	70	245	315	130	512	224MB	8-20		
	250S	75	180	670	450	515	110	1610	270	1060	280	670	670	463.5	501	1818.5	4	M16	70	245	315	130	540	250MB	8-25		
	250M	90	180	670	450	515	110	1610	270	1060	280	670	670	482.5	520	1856.5	4	M16	70	245	315	130	540	250MB	8-25		
	280S	110	180	670	450	510	110	1635	270	1060	305	670	670	544	579	1977	4	M16	70	245	315	130	536	280MB	8-28		
	280M	132	180	670	450	510	110	1635	270	1060	305	670	670	569.5	604.5	2028	4	M16	70	245	315	130	542	280MB	8-28		
	315S	160	180	670	450	490	110	1850	300	1200	350	750	750	589	640	2083	4	M20	85	315	400	150	587	GEAR CP			
200 IFWM 2015	180M	$\frac{18}{22}^5$	180	565	400	430	110	1275	205	840	230	600	490	351.5	325	1424.5	3	M16	70	245	315	130	332	180	8-14		
	180L	30	180	565	400	430	110	1275	205	840	230	600	490	370.5	344	1463.5	4	M16	70	245	315	130	337	200	8-20		
	200L	$\frac{37}{45}$	180	565	400	450	110	1470	230	940	300	600	490	425.5	377	1551.5	4	M16	70	245	315	130	356	224	8-20		
	225S	55	180	565	400	430	110	1440	230	940	270	600	600	432	388	1569	4	M16	70	245	315	130	374	224MB	8-20		
200 IFWM 2515	180M	$\frac{18}{22}^5$	160	565	450	430	85	1275	205	840	230	600	490	351.5	325	1404.5	3	M16	70	245	315	130	347	180	8-14		
	180L	30	160	565	450	430	85	1275	205	840	230	600	490	370.5	344	1443.5	4	M16	70	245	315	130	352	200	8-20		
	200L	$\frac{37}{45}$	160	565	450	450	85	1275	205	840	230	600	490	425.5	377	1531.5	4	M16	70	245	315	130	360	224	8-20		
	225S	55	160	565	450	430	85	1440	230	940	270	600	600	432	388	1549	4	M16	70	245	315	130	391	224MB	8-20		
	250S	75	160	565	450	430	85	1440	230	940	270	600	600	463.5	501	1693.5	4	M16	70	245	315	130	399	250MB	8-25		

Notes: 1. Motor output classification numbers shown are for ordinary E class totally-enclosed, fan-cooled low-voltage 3-phase squirrel-cage induction motors under JEM-1400-1983
 2. M₂ and LA dimensions marked with an asterisk vary to a certain extent, depending on motor manufacturers.
 3. Dimensions are subject to change without notice.

Dimensions



Unit: mm

Pump Model	Motor		Pump				Common base								Motor		*	Anchor bolt				Wt kg	Coupling			
	Frame	kW	P ₁	P ₂	H ₁	H ₂	A	B ₁	B ₂	B ₃	B ₄	B ₅	B ₆	M ₁	*M ₂	LA		X	Fd	Fb	Fe		Fh	Fw	IMass	CLA
200×150 IFWM	200L	32	160	670	450	450	110	1405	230	940	235	670	490	425.5	377	1636.5	4	M16	70	245	315	130	468	224	8-20	
	3216	225S	55	160	670	450	455	110	1635	270	1060	305	670	670	432	388	1654	4	M16	70	245	315	130	520	224MB	8-20
200×150 IFWM	250S	75	160	670	450	430	110	1640	270	1060	310	670	670	463.5	501	1798.5	4	M16	70	245	315	130	517	250MB	8-25	
	4026	250M	90	160	670	450	430	110	1640	270	1060	310	670	670	482.5	520	1836.5	4	M16	70	245	315	130	517	250MB	8-25
		280S	110	160	670	450	430	110	1640	270	1060	310	670	670	544	579	1957	4	M16	70	245	315	130	512	280MB	8-28
		280M	132	160	670	450	430	110	1640	270	1060	310	670	670	569.5	604.5	2008	4	M16	70	245	315	130	512	280MB	8-28
		315S	160	160	670	450	430	110	1670	300	1200	170	750	750	589	640	2063	4	M20	85	315	400	150	535	GEAR CP	
200×150 IFWM	250S	75	180	820	560	515	110	1840	300	1200	340	670	670	463.5	501	1968.5	4	M20	85	315	400	150	683	280	8-28	
	5028	250M	90	180	820	560	515	110	1840	300	1200	340	670	670	482.5	520	2006.5	4	M20	85	315	400	150	683	280	8-28
		280S	110	180	820	560	490	110	1820	300	1200	320	670	670	544	579	2127	4	M20	85	315	400	150	684	280MB	8-28
		280M	132	180	820	560	490	110	1820	300	1200	320	670	670	569.5	604.5	2178	4	M20	85	315	400	150	684	280MB	8-28
		315S	160	180	820	560	490	110	2050	340	1320	390	750	750	589	640	2233	4	M20	85	315	400	150	701	GEAP CP	
		315M	200	180	820	560	490	110	2050	340	1320	390	750	750	614.5	665.5	2284	4	M20	85	315	400	150	701	GEAR CP	
250 IFWM	225S	55	225	695	560	490	170	1545	270	1060	215	750	550	432	388	1744	4	M20	85	315	400	150	631	224MB	8-20	
	2516	250S	75	225	695	560	490	170	1650	270	1060	320	750	750	463.5	501	1888.5	4	M20	85	315	400	150	663	250MB	8-25
		250M	90	225	695	560	490	170	1650	270	1060	320	750	750	482.5	520	1926.5	4	M20	85	315	400	150	663	250MB	8-25
		280S	110	225	695	560	490	170	1850	300	1200	350	750	750	544	579	2047	4	M20	85	315	400	150	697	280MB	8-28
		280M	132	225	695	560	490	170	1850	300	1200	350	750	750	569.5	604.5	2098	4	M20	85	315	400	150	697	280MB	8-28
		315S	160	225	695	560	490	170	1850	300	1200	350	750	750	589	640	2153	4	M20	85	315	400	150	730	GEAR CP	
250×200 IFWM	250S	75	180	670	560	490	170	1650	270	1060	320	750	750	463.5	501	1818.5	4	M20	85	315	400	150	622	250MB	8-25	
	3216	250M	90	180	670	560	490	170	1650	270	1060	320	750	750	482.5	520	1856.5	4	M20	85	315	400	150	622	250MB	8-25
250×200 IFWM	280S	110	180	670	560	520	170	1650	270	1060	320	750	750	544	579	1977	4	M20	85	315	400	150	645	280MB	8-28	
	4016	280M	132	180	670	560	490	170	1850	300	1200	350	750	750	569.5	604.5	2028	4	M20	85	315	400	150	683	280MB	8-28
		315S	160	180	670	560	490	170	1850	300	1200	350	750	750	589	640	2083	4	M20	85	315	400	150	690	GEAR CP	
		315M	200	180	670	560	490	170	1850	300	1200	350	750	750	614.5	665.5	2134	4	M20	85	315	400	150	690	GEAR CP	
250×200 IFWM	280M	132	200	820	630	540	170	2120	340	1320	460	750	750	569.5	604.5	2198	4	M20	85	315	400	150	859	280MB	8-28	
	5028	315S	160	200	820	630	575	170	2120	340	1320	460	750	750	589	640	2253	4	M20	85	315	400	150	871	GEAR CP	
		315M	200	200	820	630	575	170	2120	340	1320	460	750	750	614.5	665.5	2304	4	M20	85	315	400	150	871	GEAR CP	

- Notes: 1. Motor output classification numbers shown are for ordinary E class totally-enclosed, fan-cooled low-voltage 3-phase squirrel-cage induction motors under JEM-1400-1983
 2. M₂ and LA dimensions marked with an asterisk vary to a certain extent, depending on motor manufacturers.
 3. Dimensions are subject to change without notice.



EBARA CORPORATION

Head Office:

11-1, Haneda Asahi-cho, Ohta-ku,
Tokyo, 144-8510 Japan
Phone: 81-3-3743-6111
Fax: 81-3-3745-3356
Internet homepage : <http://www.ebara.co.jp>

Sales headquarter:

1-6-27, Konan, Minato-ku, Tokyo,
108-8480, Japan
Phone: 81-3-5461-6101
Fax: 81-3-5976-0415

Please send your enquiries to the above International Division

○: Liaison Offices

■ AMERICA

UNITED STATES OF AMERICA

Ebara International Corporation (Sparks, NV)
Airvac, Inc. (Rochester, IN)
Elliott Turbomachinery Co., Inc. (Jeannette, PA)

BRAZIL

Ebara Indústrias Mecánicas e Comércio Ltda.
(Bauru, S.P.)

■ EUROPE

ENGLAND

Elliott Turbomachinery Limited (Basingstoke)

ITALY

- Italy Office (Vicenza)
Ebara Pumps Europe S.p.A. (Trento)
Sumoto S.r.l. (Vicenza)

SPAIN

Ebara Espana Bombas S.A. (Madrid)

■ ASIA

PEOPLE'S REPUBLIC OF CHINA

- Beijing Office (Beijing)
Yantai Ebara Air Conditioning Equipment Co., Ltd.
(Yantai)
Beijing Ebara Machinery Co., Ltd. (Beijing)
Ebara Machinery (Shanghai) Co., Ltd. (Shanghai)
Shanghai Ebara Engineering and Services Co., Ltd.
(Shanghai)

Ebara Qingdao Co., Ltd. (Qingdao)
Ebara Densan (Kunshan) Mfg. Co., Ltd. (Kunshan)

TAIWAN

- Taipei Office (Taipei)
Ebara-Densan Taiwan Manufacturing Co., Ltd.
(Chung Li)
Ebara-Elliott Service (Taiwan) Co., Ltd. (Taichung)
Ebara Kailay Environmental Engineering Co., Ltd.
(Taipei)

■ KOREA

Hyosung-Ebara Co., Ltd. (Seoul)
Hyosung-Ebara Environment Engineering Co., Ltd.
(Seoul)

■ SINGAPORE

- Singapore Office (Singapore)
Ebara Engineering Singapore Pte. Ltd.
(Singapore)

■ MALAYSIA

Ebara Pumps Malaysia Sdn. Bhd (Selangor)
Ebara Environmental Engineering (Malaysia) Sdn. Bhd.
(Selangor)

■ PHILIPPINES

- Manila Branch Office (Manila)
Ebara Benguet, Inc. (Laguna)

■ VIETNAM

Ebara Hai Duong Company Ltd. (Hai Duong)
Ebara Vietnam Corporation (Hanoi)

■ THAILAND

- Bangkok Office (Bangkok)
Ebara (Thailand) Limited (Bangkok)

■ INDIA

Kirloskar Ebara Pumps Limited (Pune)

■ MIDDLE-EAST

United Arab Emirates

- Middle East Office (Dubai)

■ OCEANIA

AUSTRALIA

Ebara Pumps Australia Pty. Ltd. (Bayswater, Vic)