



**EBARA**



ISO 9001 : 2000  
Lic no: OEC22090



FS 8001-6

# END SUCTION VOLUTE PUMP

Model **FSA**

60Hz

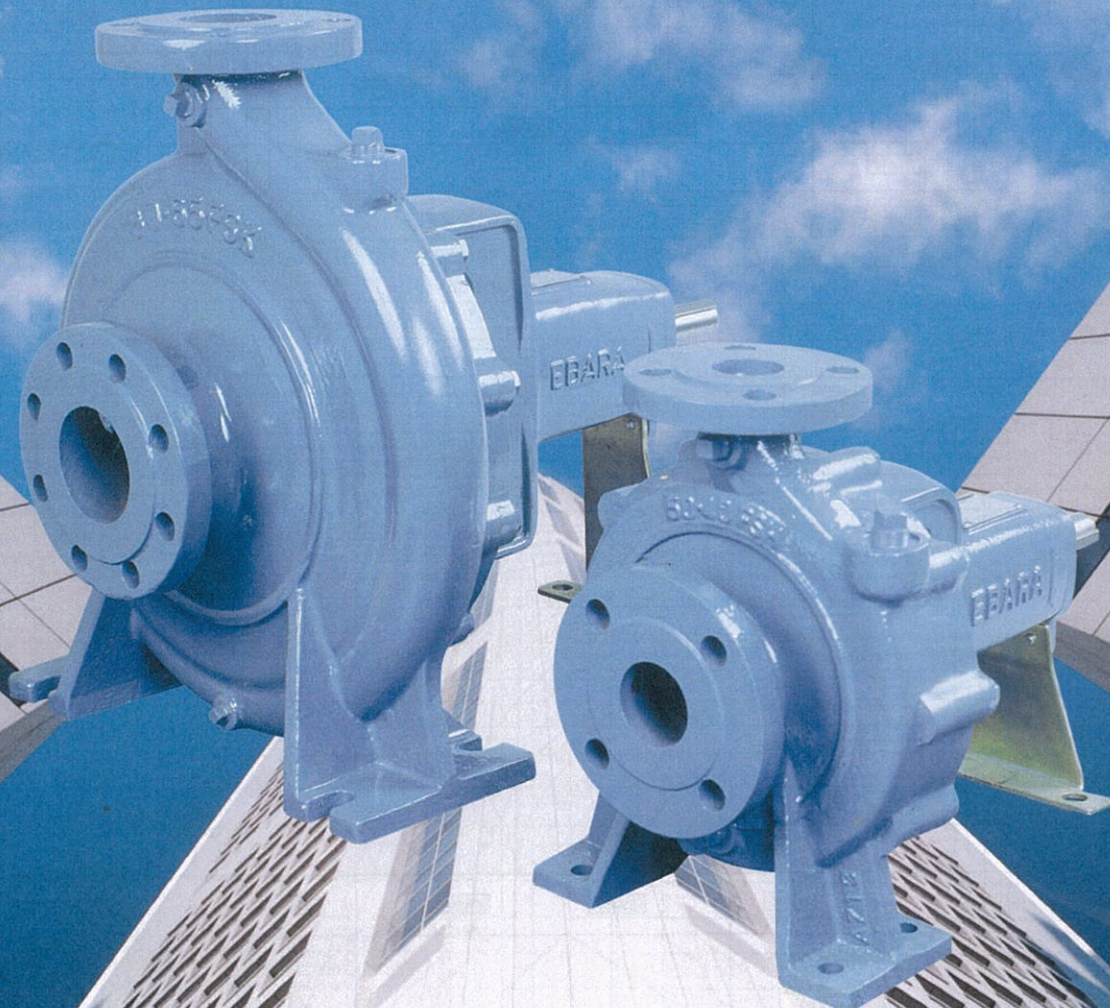

## MODEL CODE

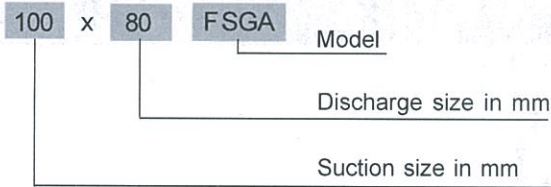

## SELECTION CHART (60 Hz)

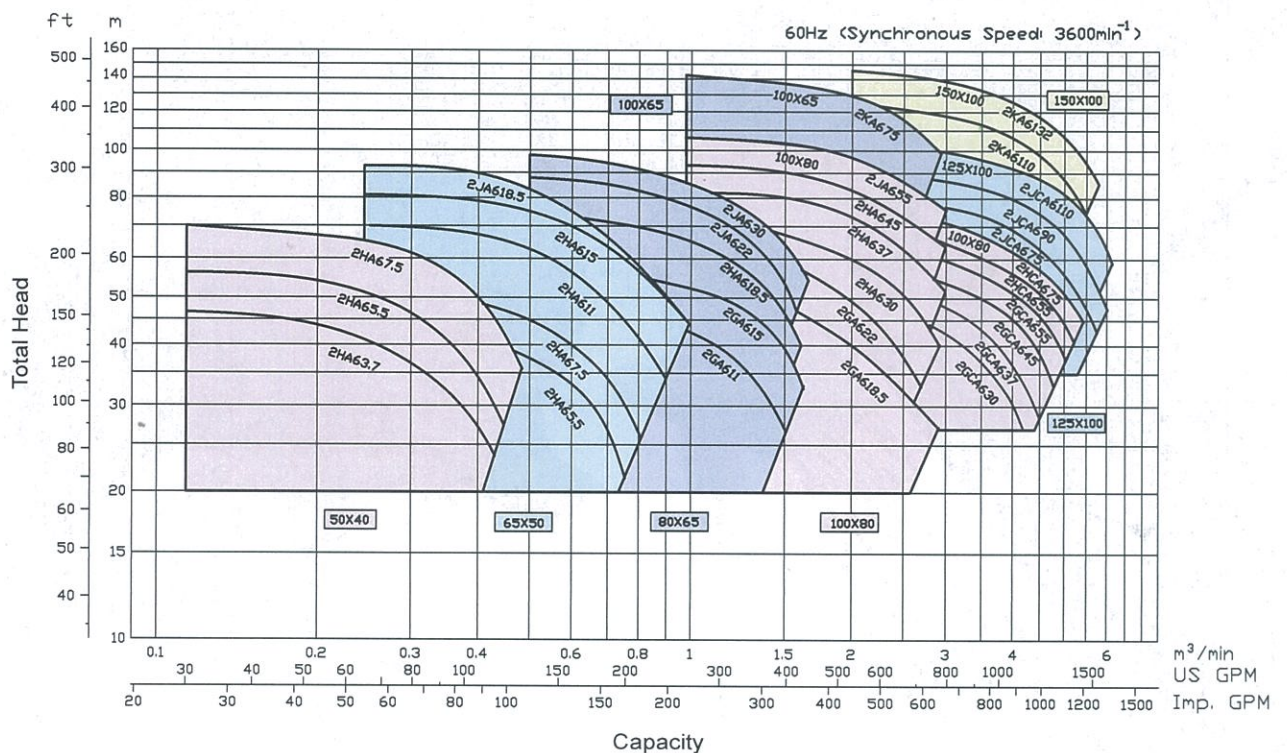
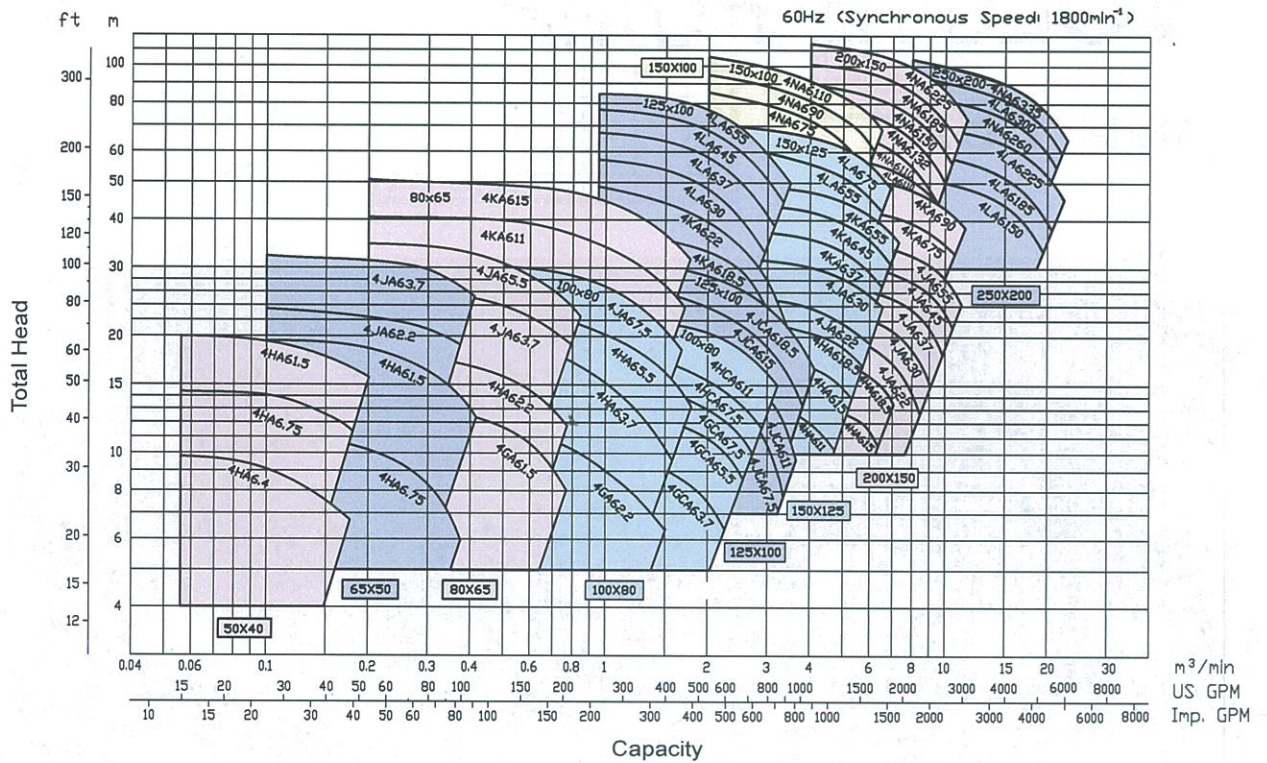

# END SUCTION VOLUTE PUMP

## FEATURES

1. Easy removal and maintenance, BPO (Back Pull Out) system allows all rotating element to be removed without disconnecting suction and discharge pipework.
2. Top centerline dischargen foot support under casing for maximum resistance to misalignment and distorsion from pipe loads
3. Non-overload design to ensure stable performance for all applications.
4. Wide range application with flow capacity up to 22m<sup>3</sup>/min
5. Higher working pressure up to 16 Bar.

## APPLICATION

1. Industrial use
2. Water supply
3. Hot and cold water supply
4. For swimming pool
5. Sprinkling
6. Air-conditioning
7. Fire-fighting application

## SECTIONAL VIEW ( General)

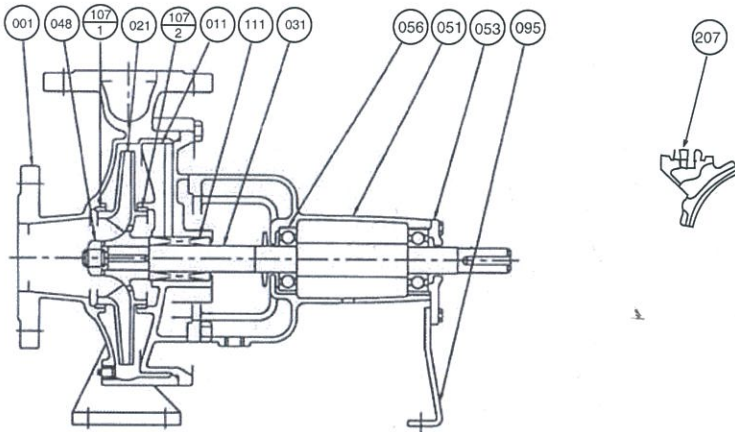

No.	Part Name	Material	Qty
207	Plug	Steel	1
111	Mechanical Seal	-	
107-2	Casing Ring	Bronze	1
107-1	Casing Ring		
095	Stay	Steel	1
056	Ball Bearing	-	2
053	Bearing Cover	Cast Iron	1
051	Bearing Housing		
048	Impeller Nut	Brass	1
031	Shaft	Stainless Steel	
021	Impeller	Bronze	1
011	Casing Cover	Cast Iron	
001	Casing		

## SPECIFICATION

Description		Standard		Optional	
		2 poles model	4 poles model	2 poles model	4 poles model
Liquid	Name	Clean water			
	Temperature	Below 80°C (176°F)			
Max. Working Pressure		10 bar (10.2 kgf/cm <sup>2</sup> ) for standard flange JIS 10K RF 16 bar (16.3 kgf/cm <sup>2</sup> ) for standard flange JIS 16K RF		16 bar (16.3 kgf/cm <sup>2</sup> )	
Synchronous Speed		3600 min <sup>-1</sup>	1800 min <sup>-1</sup>		
Instalation		Indoors		Outdoors	
Construction	Impeller	Enclosed			
	Shaft seal	Mechanical seal		Gland Packing	
	Sealing	Self flushing		External flushing	
	Bearing	Sealed ball bearing		Oil bath (some models only)	
Flange	Suction & Discharge	Suction < φ 150 mm, except 100x65 FSKA : JIS 10K RF		16 bar : JIS 16K RF; DIN PN-16	
		100x65 FSKA : JIS 16K RF		DIN PN-16	
		Suction = φ 150 mm, except below models : JIS 10K RF		16 bar : JIS 16K RF; DIN PN-16	
		150x100 FSKA; 150x100 FSNA : JIS 16K RF		DIN PN-16	
		Suction = φ 200 mm, except below models : JIS 10K RF		16 bar : JIS 16K RF; DIN PN-16	
200x150 FSLA; 200x150 FSNA : JIS 16K RF		DIN PN-16			
Suction = φ 250 : JIS 16K RF					
Material	Casing	Cast Iron		Ductile Cast Iron (FCD)	
	Impeller	Bronze Casting (CAC406/BC6)		Cast iron; Ductile Cast Iron (FCD)	
	Shaft	403 Stainless steel		304; 316 Stainless steel	
	Seal	Mechanical Seal: Ceramic/Carbon/NBR		Gland Packing : Teflon (PTFE) impregnated Mechanical Seal : SiC/SiC	
Accessories	Bare shaft			Priming funnel ; valve; Companion Flange	
	With motor	Common base, Coupling, Coupling guard		Priming funnel ; valve; Companion Flange	

# ■ BARE SHAFT PUMP

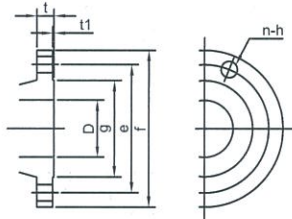
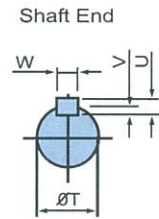
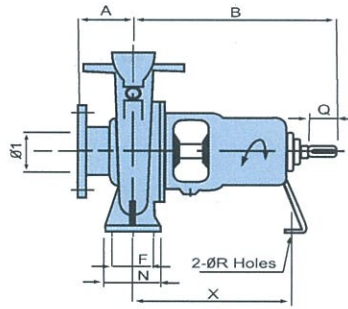
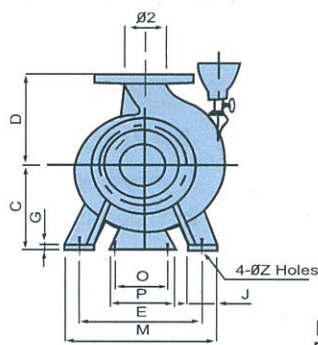

Dimension - Flange (JIS 10K RF)

D	f	e	g	t1	t	n	h
mm	mm	mm	mm	mm	mm		mm
40	140	105	81	2	20	4	19
50	155	120	96	2	20	4	19
65	175	140	116	2	22	4	19
80	185	150	126	2	22	8	19
100	210	175	151	2	24	8	19
125	250	210	182	2	24	8	23
150	280	240	212	2	26	8	23
200	330	290	262	2	26	12	23

Dimension - Flange (JIS 16K RF)

D	f	e	g	t1	t	n	h
mm	mm	mm	mm	mm	mm		mm
65	175	140	116	2	22	8	19
100	225	185	160	2	26	8	23
150	305	260	230	2	28	12	25
200	350	305	275	2	30	12	25
250	430	380	345	2	34	12	27

Dimension - Pump (JIS 10K RF)

Model	Size		Pump														Shaft					wt kg										
	φ1	φ2	A	B	C	D	E	F	G	J	M	N	O	P	R	X	Z	T	Q	U	V		W									
50x40 FSHA	50	40	80	360	160	180	190	70	12	50	240	100	110	150	17	285	15	24	50	7	4	8	37									
65x50 FSHA	65	50	100	360	160	180	212	70	12	50	265	100	110	150	17	285	15	24	50	7	4	8	42									
65x50 FSJA					180	225	250	95	14	65	320	125												49								
80x65 FSGA	80	65	100	360	160	180	212	70	12	50	265	100	110	150	17	285	15	24	50	7	4	8	39									
80x65 FSHA					200	200	200	95	14	65	320	125												48								
80x65 FSJA					180	225	250	95	14	65	320	125												60								
80x65 FSKA					125	470	225	280	315	120	16	80												400	160	370	19	32	80	8	5	10
100x80 FSGA	100	80	100	360	160	200	212	95	14	65	280	125	110	150	17	285	15	24	50	7	4	8	49									
100x80 FSHA					180	225	250	15	80	320	125	62																				
100x80 FSJA					200	250	280	120	15	80	360	160												70								
100x80 FSGCA					225	250	250	15	80	320	125	62																				
100x80 FSHCA					125	360	180	250	280	95	14	65												345	125	15	32	80	8	5	10	65
125x100 FSJCA					360	225	280	315	120	16	80	400												160	110	150	17	285	19	32	80	8
125x100 FSKA	470	250	315	400	150	20	100	500	200	110	150	17	370	24	42	110	8	5	10	128												
125x100 FSLA	530	280	355	400	150	20	100	500	200	110	150	17	370	24	42	110	8	5	10	168												
150x125 FSHA	150	125	140	470	250	315	315	120	15	80	400	160	110	150	17	370	19	32	80	8	5	10	120									
150x125 FSJA					355	16	100	500	200	310	24	42												110	128							
150x125 FSKA					280	400	150	20	100	500	200	310												24	42	110	12	170				
150x125 FSLA					315	400	20	100	500	200	310	24												42	110	205						
200x150 FSHA					470	280	355	400	150	18	100	500												200	110	150	17	370	24	42	110	8
200x150 FSJA	530	280	375	400	150	18	100	500	200	110	150	17	370	24	42	110	8	5	10	183												
200x150 FSKA	670	315	400	450	20	550	140	180	19	500	48	110	9	5.5	14	222																

Unit:mm, unless otherwise stated

Dimension - Pump (JIS 16K RF)

Model	Size		Pump														Shaft					wt kg	
	φ1	φ2	A	B	C	D	E	F	G	J	M	N	O	P	R	X	Z	T	Q	U	V		W
100x65 FSKA	100	65	125	360	225	280	315	120	16	80	400	160	110	150	17	285	19	38	80	8	5	10	106
150x100 FSKA	150	100	140	530	250	315	315	120	16	80	400	160	90	120	15	370	19	42	95	8	5	12	146
150x100 FSNA			180	670	375	450	450	150	20	100	550	200	140	180	19	500	24	48	110	9	5.5	14	365
200x150 FSLA	200	150	162	670	315	450	450	150	20	100	550	200	140	180	19	500	24	48	110	9	5.5	14	336
200x150 FSNA			182	670	375	560	450	150	20	100	550	200	140	180	19	500	24	60	110	11	7	18	488
250x200 FSLA	250	200	180	670	385	560	560	250	25	100	660	315	140	180	19	500	24	60	110	11	7	18	505
250x200 FSNA			200	820	435	630	560	250	25	100	660	315	160	200	19	630	27	74	125	12	8	20	642

Unit:mm, unless otherwise stated

All specification subject to change without prior notice.



## EBARA CORPORATION

Head Office, Tokyo  
 International Division, Tokyo  
 Singapore Office  
 Beijing Office  
 Bangkok Office  
 Hanoi Office  
 Jakarta Office & Factory  
 Kuala Lumpur Office  
 Manila Office  
 Taipei Office  
 Dubai Office

Phone : 81 - 3 - 3743 - 6111  
 Phone : 81 - 3 - 5461 - 6111  
 Phone : 65 - 862 - 3536  
 Phone : 86 - 10 - 6590 - 8150  
 Phone : 66 - 2 - 216 - 4935  
 Phone : 84 - 4 - 826 - 3601  
 Phone : 62 - 21 - 8740852  
 Phone : 603 - 5569 - 1655  
 Phone : 63 - 2 - 816 - 7524  
 Phone : 886 - 2 - 567 - 1310  
 Phone : 971 - 4 - 883 - 8889

Fax : 65 - 861 - 0589  
 Fax : 86 - 10 - 6590 - 8158  
 Fax : 66 - 2 - 216 - 4937  
 Fax : 84 - 4 - 826 - 3617  
 Fax : 62 - 21 - 8740033  
 Fax : 603 - 5569 - 3766  
 Fax : 63 - 2 - 817 - 6662  
 Fax : 886 - 2 - 567 - 1046  
 Fax : 971 - 4 - 883 - 5307

## Distributor / Dealer