

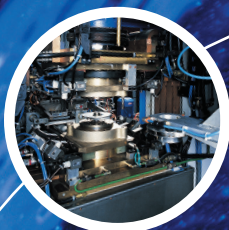

CDX - 2CDX



Centrifugal Pumps



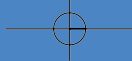
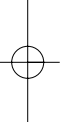
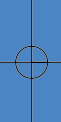



INDEX



CDX	pag. 4
SPECIFICATIONS	pag. 6
Applications	pag. 6
Technical features	pag. 6
Technical data	pag. 6
Type key	pag. 6
Performance chart	pag. 6
Performance table	pag. 6
Pump	pag. 7
Motor	pag. 7
Specification of materials and motors	pag. 7
Electrical data	pag. 8
Sound pressure level emitted by electro-pumps	pag. 8
EBARA TECHNOLOGY	pag. 9
PERFORMANCE CURVES	pag. 10
SECTIONAL VIEW	pag. 13
MECHANICAL SEAL	pag. 14
DIMENSIONS	pag. 15
INSTALLATIONS	pag. 16
2CDX	pag. 18
SPECIFICATIONS	pag. 20
Applications	pag. 20
Technical features	pag. 20
Technical data	pag. 20
Type key	pag. 20
Performance chart	pag. 20
Performance table	pag. 20
Pump	pag. 21
Motor	pag. 21
Specification of materials and motors	pag. 21
Electrical data	pag. 22
Sound pressure level emitted by electro-pumps	pag. 22
PERFORMANCE CURVES	pag. 23
SECTIONAL VIEW	pag. 26
MECHANICAL SEAL	pag. 27
DIMENSIONS	pag. 28
INSTALLATIONS	pag. 29

CDX

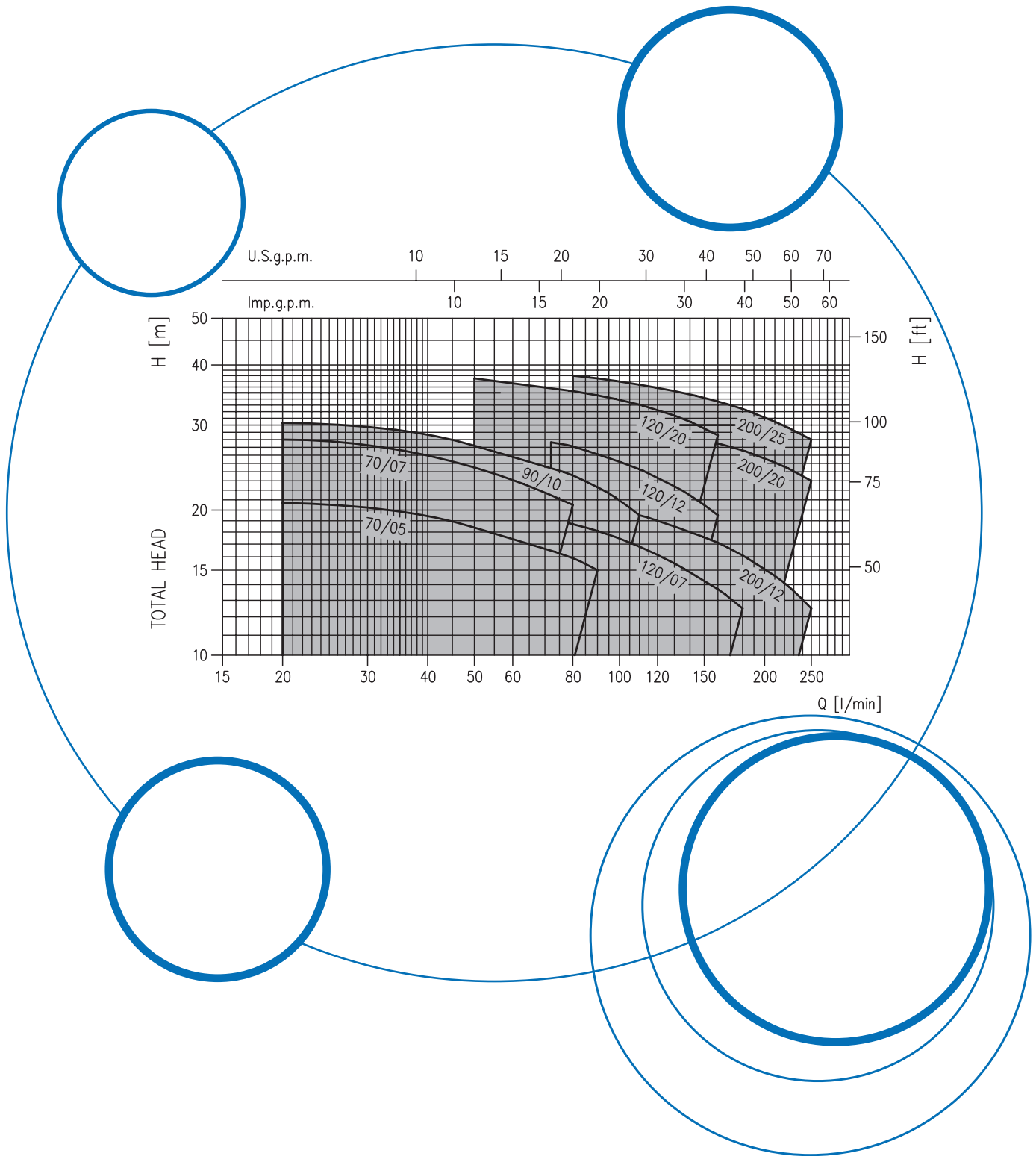

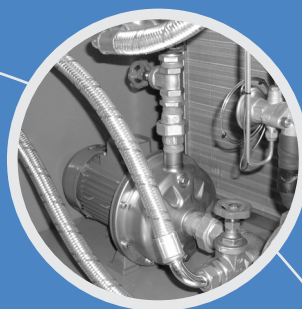
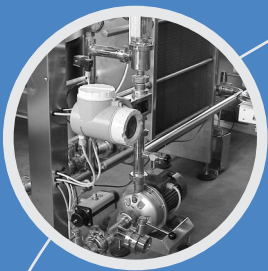

CDX

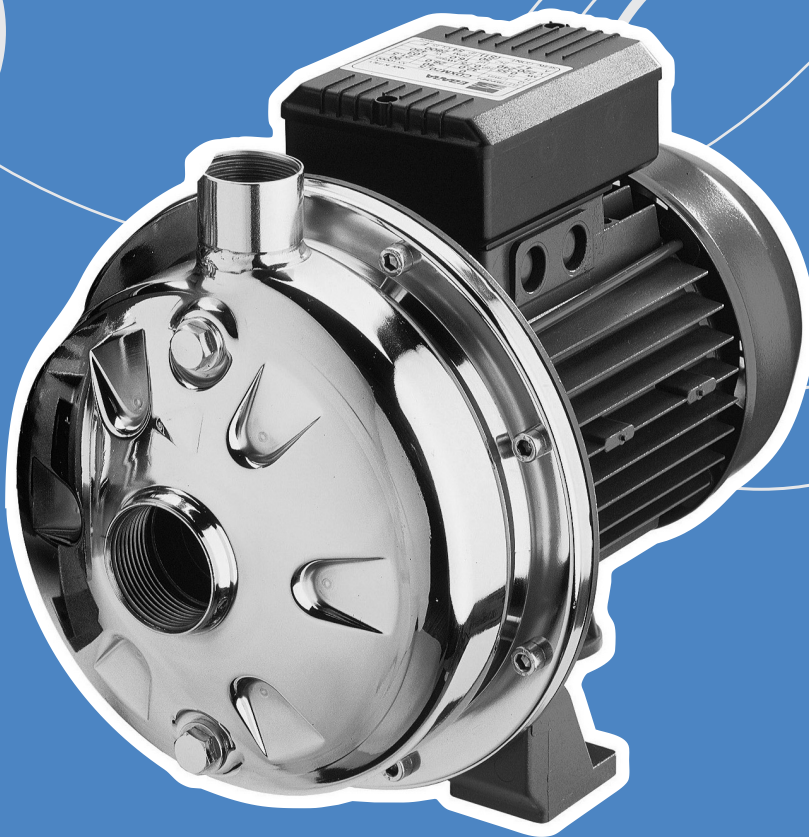



CDX

**CENTRIFUGAL PUMPS
SINGLE IMPELLER IN AISI 304**

SPECIFICATIONS



Single impeller centrifugal pumps with hydraulic components manufactured from stainless steel AISI 304 (316 option).

APPLICATIONS

- Washing machines
- Water treatment plants
- Conditioning plants
- Heating plants
- Enological and food plants
- Moderately aggressive fluids pumping
- Air / humidification treatment plants

TECHNICAL FEATURES

- Hydraulic robust construction
- High performances and efficiency
- Integrated volute obtained from hydro-forming process
- Low noise
- Compact dimensions

TECHNICAL DATA

- Capacity up to 15 m³/h
- Total head up to 42 m
- T.E.F.C. 2 poles motor
- Insulation class F
- Protection degree IP55
- 1~230V ± 10% 50Hz, 3~230/400V ± 10% 50Hz
- Permanent split capacitor and automatic thermal overload protection for single-phase version
- Thermal protection to be provided by the user for three-phase version
- DNA 1"½ for CDX200, DNA 1"¼ for the other models
- DNM 1"

PERFORMANCE CHART
(according to ISO 9906 Annex A)

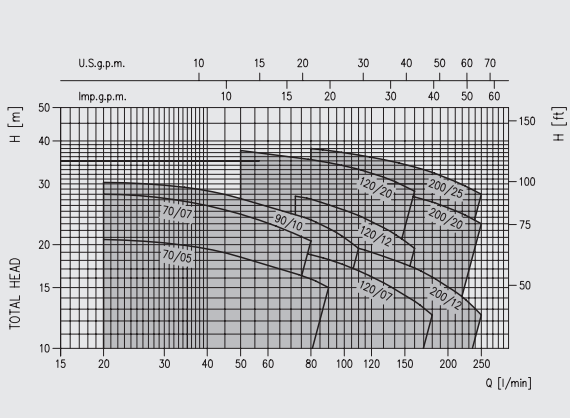

TYPE KEY

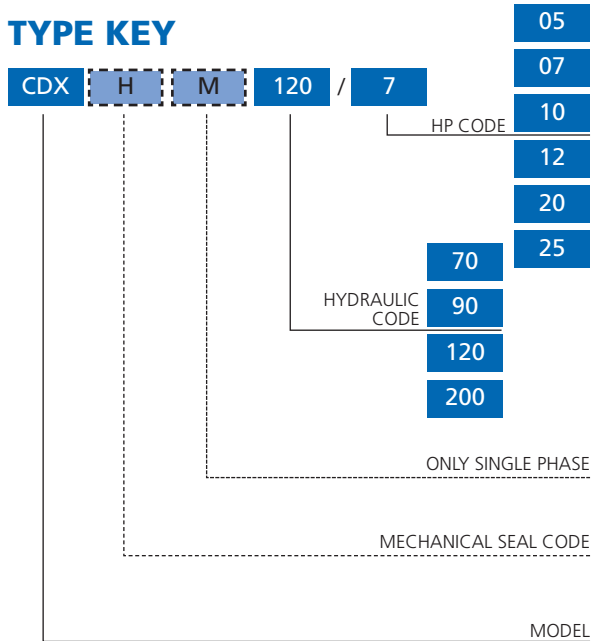

PERFORMANCE TABLE

Pumps type		Power		Q=Capacity	Q=Capacity									
Single-phase	Three-phase	kW	HP		l/min	20	50	80	90	110	130	160	180	210
				m ³ /h	1,2	3	4,8	5,4	6,6	7,8	9,6	10,8	12,6	15
H=Total manometric head in meters														
CDXM 70/05	CDX 70/05	0,37	0,5	20,7	18,4	15,9	15	-	-	-	-	-	-	-
CDXM 70/07	CDX 70/07	0,55	0,8	28	24,5	20,5	-	-	-	-	-	-	-	-
CDXM 90/10	CDX 90/10	0,75	1	30,3	27,2	23,6	22,3	19,5	-	-	-	-	-	-
CDXM 120/07	CDX 120/07	0,55	0,8	-	20,5	18,7	18,1	16,8	15,5	13,7	12,5	-	-	-
CDXM 120/12	CDX 120/12	0,9	1,2	-	29,5	27,1	26,1	24,3	22,4	19,5	-	-	-	-
CDXM 120/20	CDX 120/20	1,5	2	-	37,5	35,3	34,6	33,1	31,4	28,6	-	-	-	-
CDXM 200/12	CDX 200/12	0,9	1,2	-	-	20,6	20,2	19,5	18,5	17,1	16,1	14,6	12,5	-
CDXM 200/20	CDX 200/20	1,5	2	-	-	31	30,6	29,7	28,9	27,5	26,6	25,1	23	-
-	CDX 200/25	1,8	2,5	-	-	38	37,5	36,4	35,3	33,6	32,4	30,5	28	-

PUMP		
Liquid Handled	Type of liquid	Clean water
	Max temperature [°C]	60 (CDX 70/05-70/07-90/10) standard
		90 standard
		110 (CDXH and CDXHS) standard
Min temperature [°C]	-10	
Maximum working pressure	[MPa]	0.8
Construction	Impeller	Closed centrifugal type
	Shaft seal type	Mechanical seal
	Bearing	Sealed ball bearing
Pipe Connection	Suction	G 1 1/4 (G 1 1/2 CDX200)
	Discharge	G 1
Material	Casing	AISI 304
	Impeller	AISI 304
	Casing cover	AISI 304
	Shaft seal	Ceramic/Carbon/NBR (for CDX) Standard
		Ceramic/Carbon/FPM (for CDXH)
		SiC/SiC/FPM (for CDXHS)
Shaft	AISI 303 (Wet extension)	
Bracket	Aluminium	

MOTOR			
Type		Electric - TEFC	
		Single Phase	Three Phase
No. of Poles		2	
Rotation speed	[min-1]	≈ 2800	
Insulation Class		F	
Protection degree		IP 55	
Power rating	[kW]	0.37 ÷ 1.5	0.37 ÷ 1.8
	[HP]	0.5 ÷ 2	0.5 ÷ 2.5
Frequency	[Hz]	50	
Voltage	[V]	230 ±10%	230/400 ±10%
Capacitor		Built in	-
Over load protection		Built in	Provided by the user
Casing material		Aluminium	
Base material/motor support		Aluminium	

SPECIFICATION OF MATERIALS AND MOTORS

Standard motors for ambient temperatures till 40°C and altitude till 1000 m.
For different applications, please contact our Sales Network.



CDX

**CENTRIFUGAL PUMPS
SINGLE IMPELLER IN AISI 304**

SPECIFICATIONS

ELECTRICAL DATA

TYPE PUMPS		POWER		CAPACITOR		POWER INPUT		FULL LOAD CURRENT		
Single Phase 230 V 50 Hz	Three Phase 230/400 V 50 Hz	kW	HP	Single Phase µF	Vc	[kW]		Single Phase	Three Phase	
						Single Phase	Three Phase		230 V	400 V
CDXM 70/05	CDX 70/05	0.37	0.5	12.5	450	0.7	0.7	3.1	2.4	1.4
CDXM 70/07	CDX 70/07	0.55	0.75	16	450	1	1	4.6	3.5	2
CDXM 90/10	CDX 90/10	0.75	1	20	450	1.2	1.1	5.6	4	2.3
CDXM 120/07	CDX 120/07	0.55	0.75	16	450	1	1	4.6	3.2	1.9
CDXM 120/12	CDX 120/12	0.9	1.2	31.5	450	1.6	1.6	6.9	5.2	3
CDXM 120/20	CDX 120/20	1.5	2	40	450	2.1	2.1	9.3	7	4
CDXM 200/12	CDX 200/12	0.9	1.2	31.5	450	1.4	1.3	6.3	4.7	2.7
CDXM 200/20	CDX 200/20	1.5	2	40	450	2.3	2.1	10.7	7	4
-	CDX 200/25	1.8	2.5	-	-	-	2.8	-	8.2	4.8

SOUND PRESSURE LEVEL EMITTED BY ELECTRO-PUMPS

Power kW	MOTOR		50 Hz LpA - dB (A)	60 Hz LpA - dB (A)*
	Size Mec			
0.37	71		61	65
0.55	71		62	66
0.75	71		62	66
0.9	71		62	66
1.1	80		64	68
1.5	80		64	68
1.85	80		65	--
2.2	90		68	72
3	90		68	72
4	100		--	77

* Mean value of several measures at 1m distance around the pump. Tolerance ± 2.5 dB.

CDX

**CENTRIFUGAL PUMPS
SINGLE IMPELLER IN AISI 304**

EBARA TECHNOLOGY



EBARA TECHNOLOGY

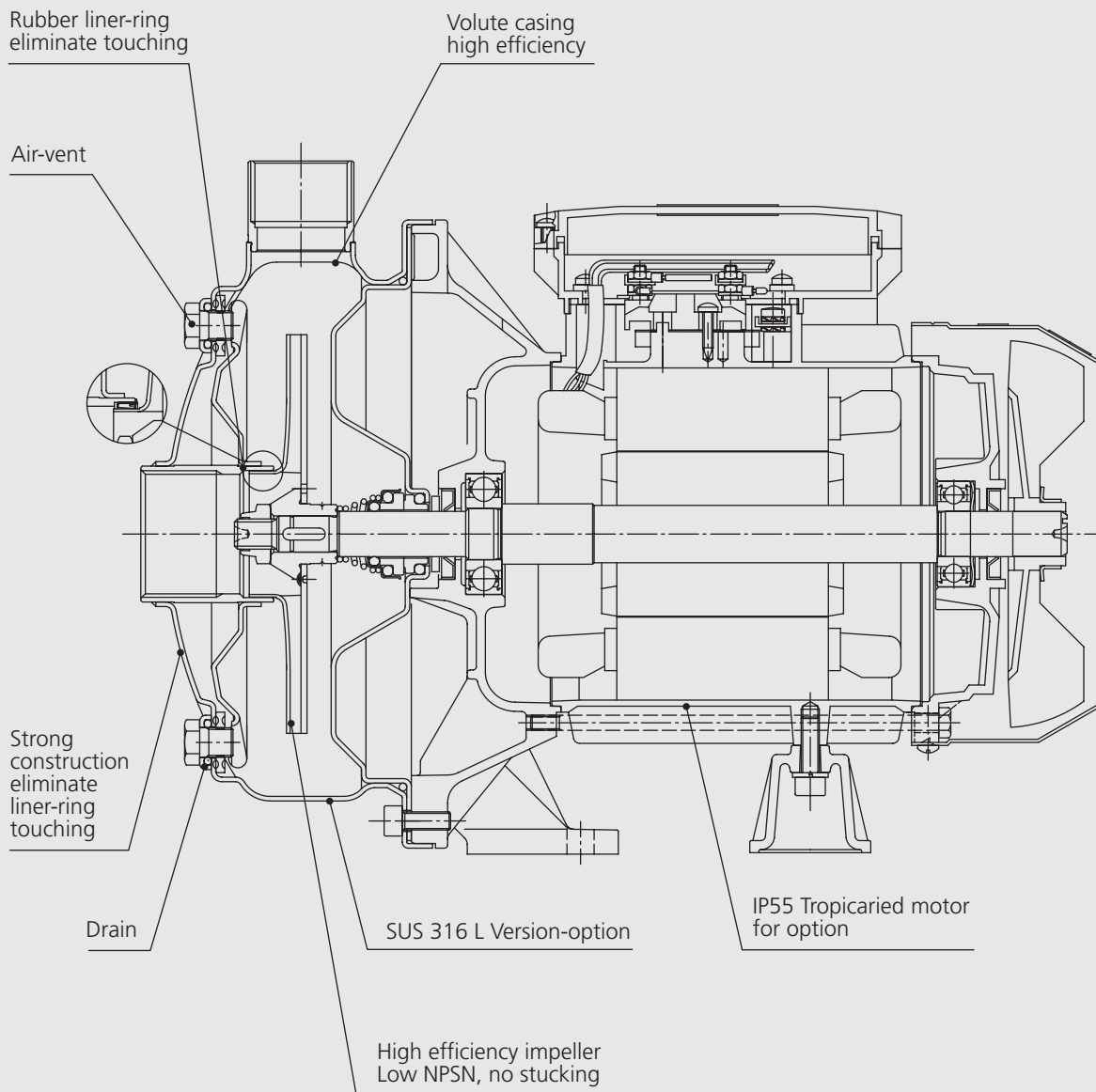



CDX

CENTRIFUGAL PUMPS SINGLE IMPELLER IN AISI 304

PERFORMANCE CURVES

CDX 70/05 Impeller diameter = 132
CDX 70/07 Impeller diameter = 157
CDX 90/10 Impeller diameter = 157

2800 m⁻¹

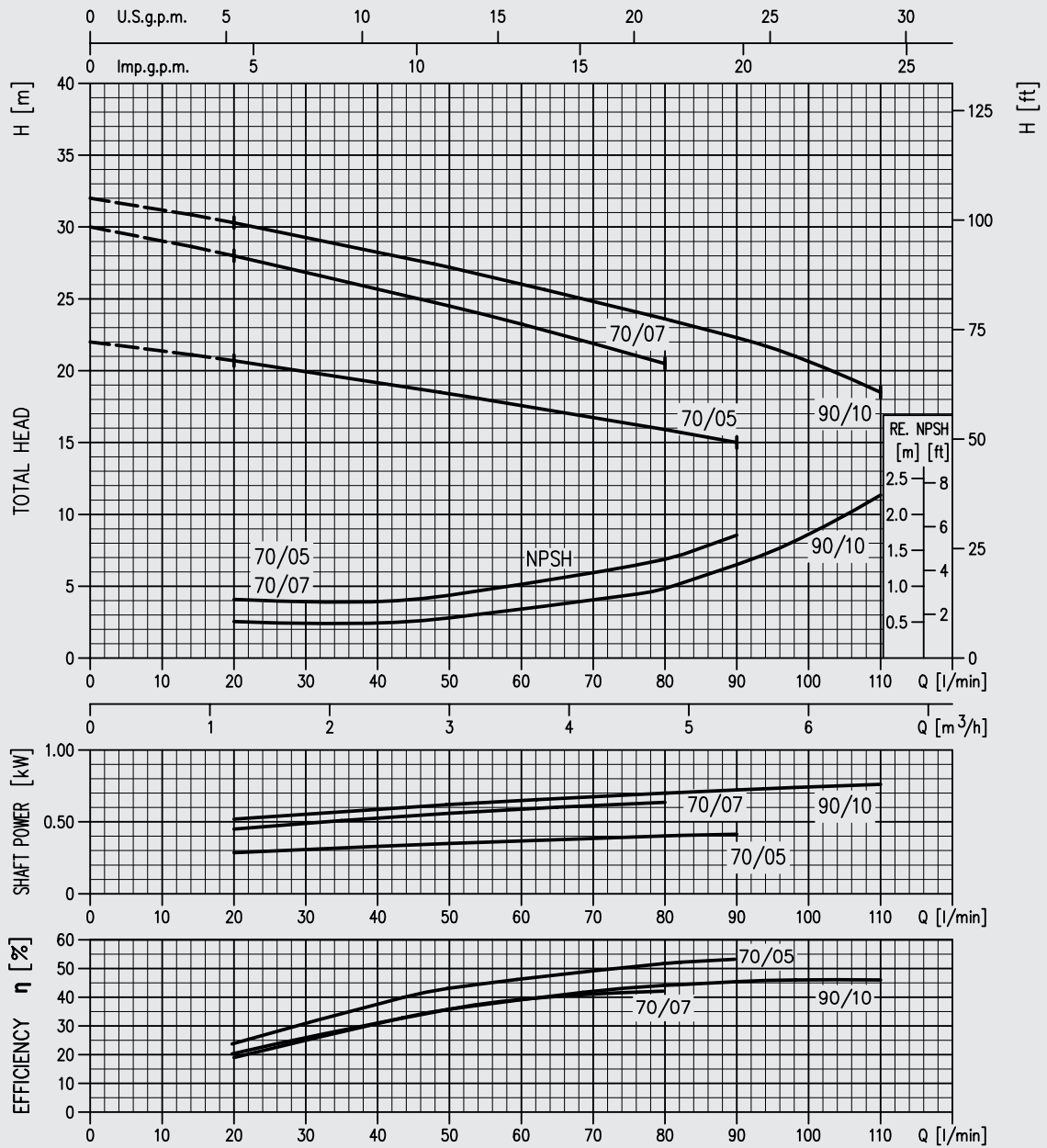

The hydraulic performances indicated refer to the tests executed with water at 20°C according to standard ISO 9906, annex A. On the values of NPSH indicated, we suggest you to add a security margin of 0,5 m. in order to guarantee the practical working.

CDX 120/07 (0.55 kW) Impeller diameter = 132
CDX 120/12 (0.90 kW) Impeller diameter = 157
CDX 120/20 (1.50 kW) Impeller diameter = 176

2800 m¹

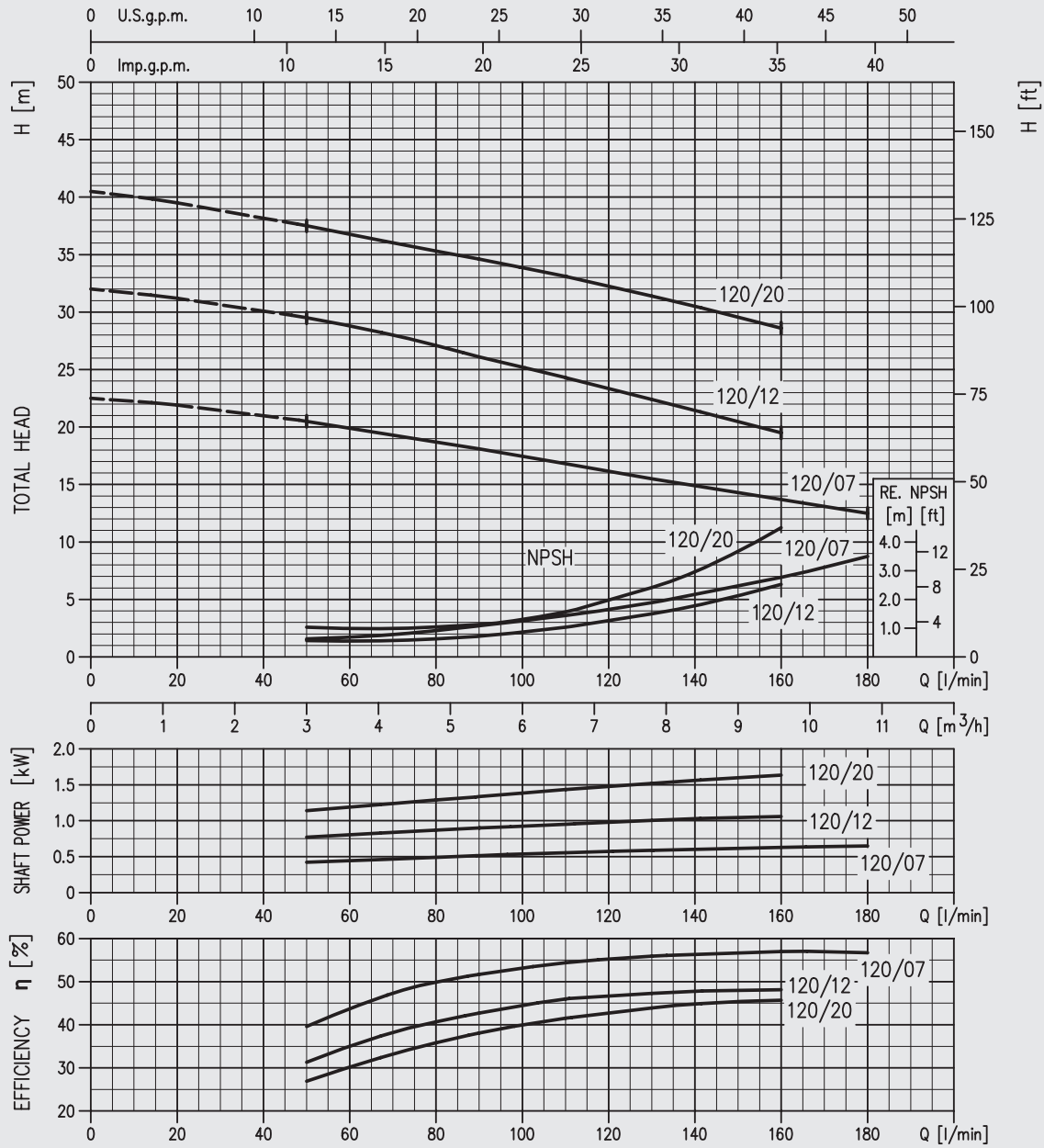



CDX

CENTRIFUGAL PUMPS SINGLE IMPELLER IN AISI 304

PERFORMANCE CURVES

CDX 200/12 (0.9 kW) Impeller diameter = 132
 CDX 200/20 (1.5 kW) Impeller diameter = 157
 CDX 200/25 (1.8 kW) Impeller diameter = 176

2800 m⁻¹

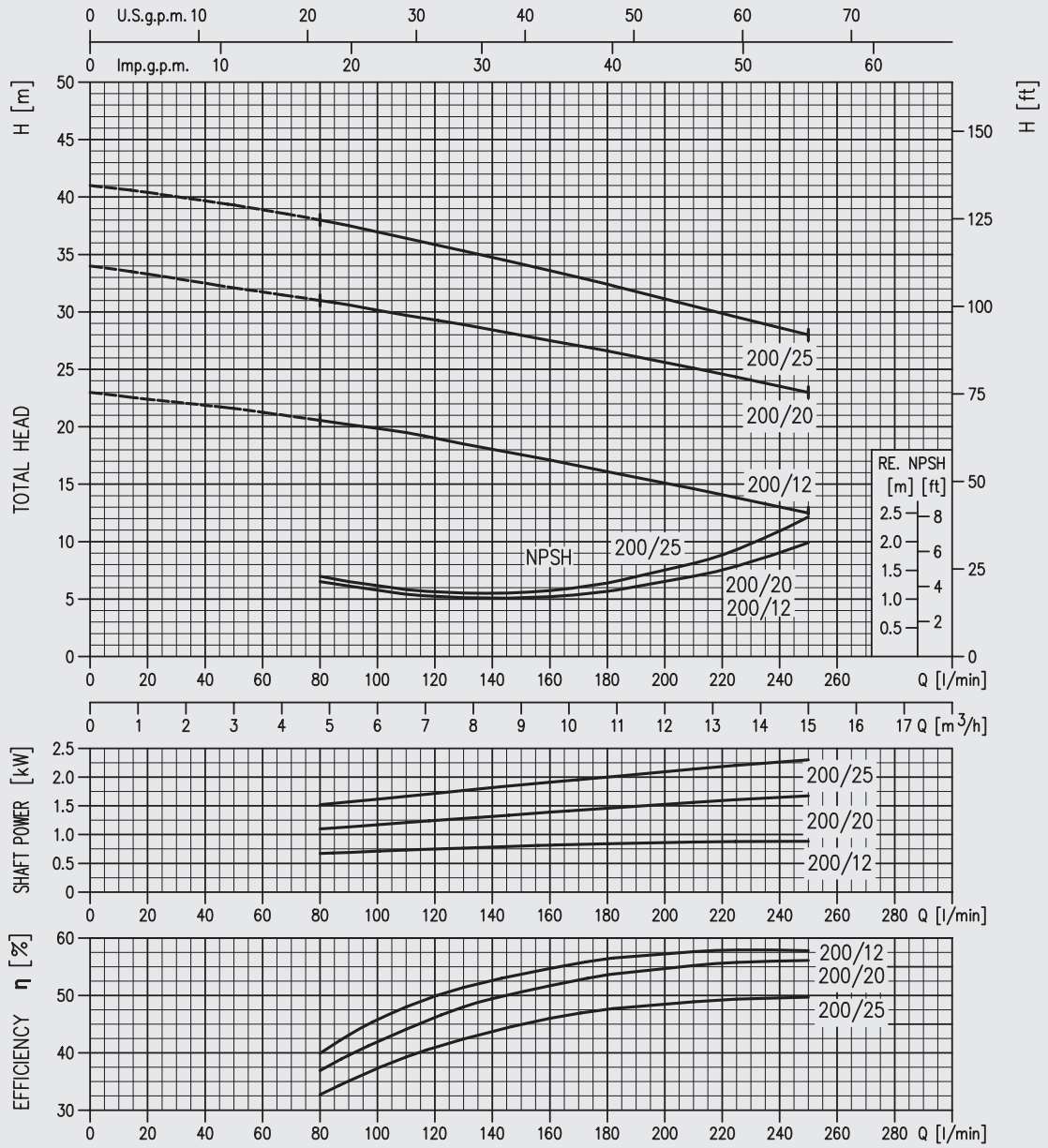

EXPLODED VIEW AND LIST OF COMPONENT

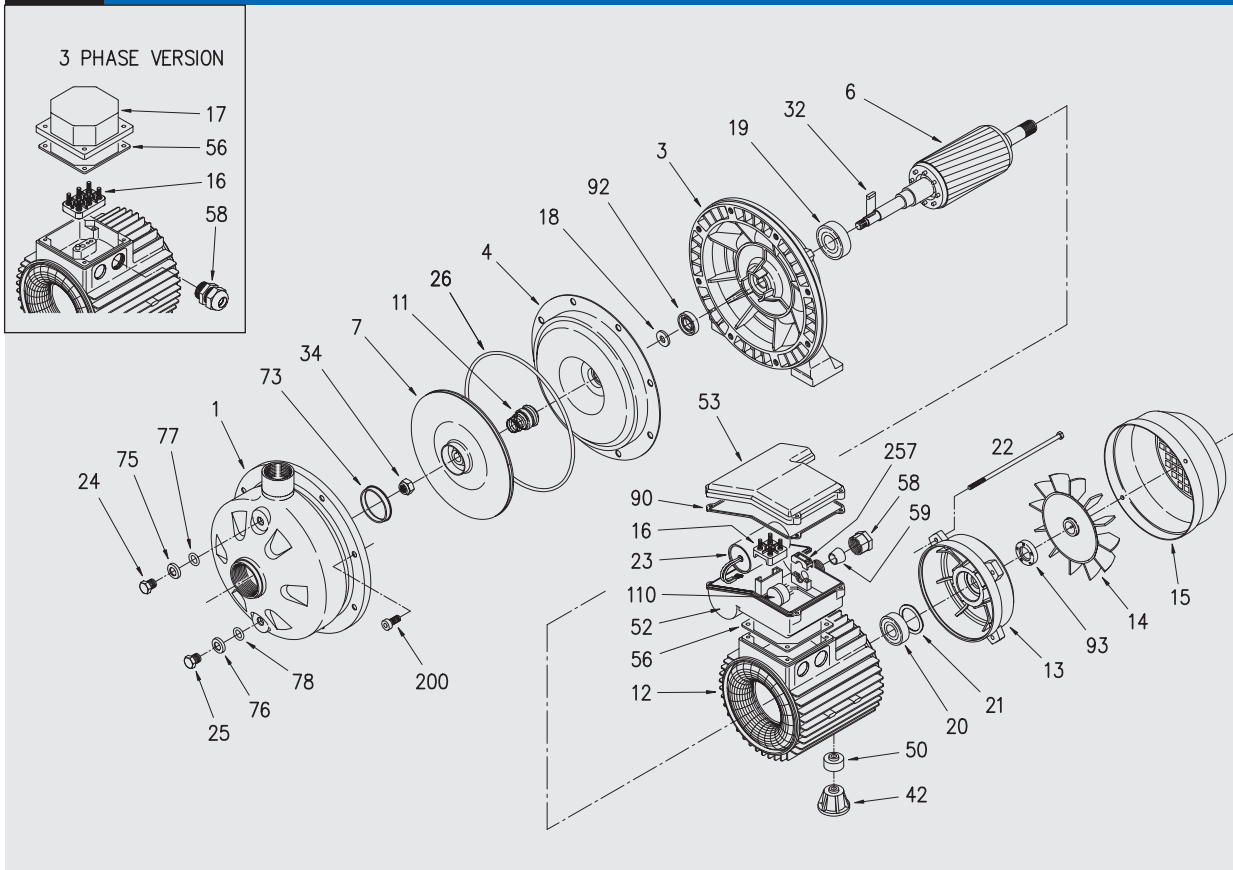

N°	PART NAME	MATERIAL	Q.TY	N°	PART NAME	MATERIAL	Q.TY
1	Casing	AISI 304	1	25	Drain plug	AISI 303	1
3	Motor bracket	Aluminium	1	26	O-ring	NBR [3]	1
4	Casing cover	AISI 304	1	32	Key	AISI 304	1
6	Shaft with rotor	AISI 303 (Part in contact with liquid)	1	34	Impeller nut	AISI 304	1
7	Impeller	AISI 304	1	42	Motor support	Aluminium	1
11	Mechanical seal	Carbon/Ceramic/NBR [3]	1	52	Terminal box [1]	Polypropilene	1
12	Motor frame with stator	-	1	53	Terminal box cover [1]	Polypropilene	1
13	Motor cover	Aluminium	1	56	Box gasket	NBR	1
14	Fan	Polypropilene	1	73	Casing ring	AISI 304 [4]	1
15	Fan cover	Fe P04 Zinked	1	75	Washer	AISI 304	1
16	Terminal board	-	1	76	Washer	AISI 304	1
17	Terminal box cover [2]	Aluminium	1	77	O-ring	NBR [3]	1
18	Splash ring	NBR	1	78	O-ring	NBR [3]	1
19	Pump side ball bearing	-	1	90	Cover gasket [1]	NBR	1
20	Fan side ball bearing	-	1	92	Lip seal	-	1
21	Adjusting ring	Steel C70	1	93	Lip seal	-	1
22	Tie rod	Fe 42 Zinked	4	110	Protector [1]	-	1
23	Capacitor [1]	-	1	200	Screw	Stainless steel A2 UNI7323	8
24	Priming plug	AISI 303	1				

[1] Only for single phase
 [2] Only for three phase
 [3] FPM for CDXH and CDXHS
 [4] NBR for: CDX 70/05, 70/07, 90/10
 FPM for CDXH 70/05, 70/07, 90/10 and CDXHS 70/05, 70/07, 90/10



CDX CENTRIFUGAL PUMPS SINGLE IMPELLER IN AISI 304

MECHANICAL SEAL

MECHANICAL SEAL

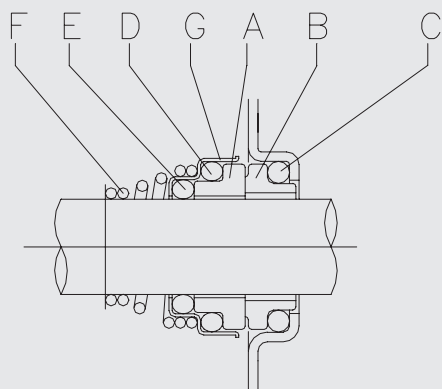

On request special mechanical seal suitable for different fluids.

REF	PART NAME	MATERIAL		
		Standard version (CDX)	(CDXH) Optional	(CDXHS)
A	Rotary seal ring	Ceramic	Ceramic	Silicon carbide
B	Stationary seal ring	Carbon graphite	Carbon graphite	Silicon carbide
C	O Ring	NBR	FPM	FPM
D	O Ring	NBR	FPM	FPM
E	O Ring	NBR	FPM	FPM
F	Self driving spring	AISI 316	AISI 316	AISI 316
G	Frame	AISI 304	AISI 304	AISI 316

CDX

**CENTRIFUGAL PUMPS
SINGLE IMPELLER IN AISI 304**

DIMENSIONS

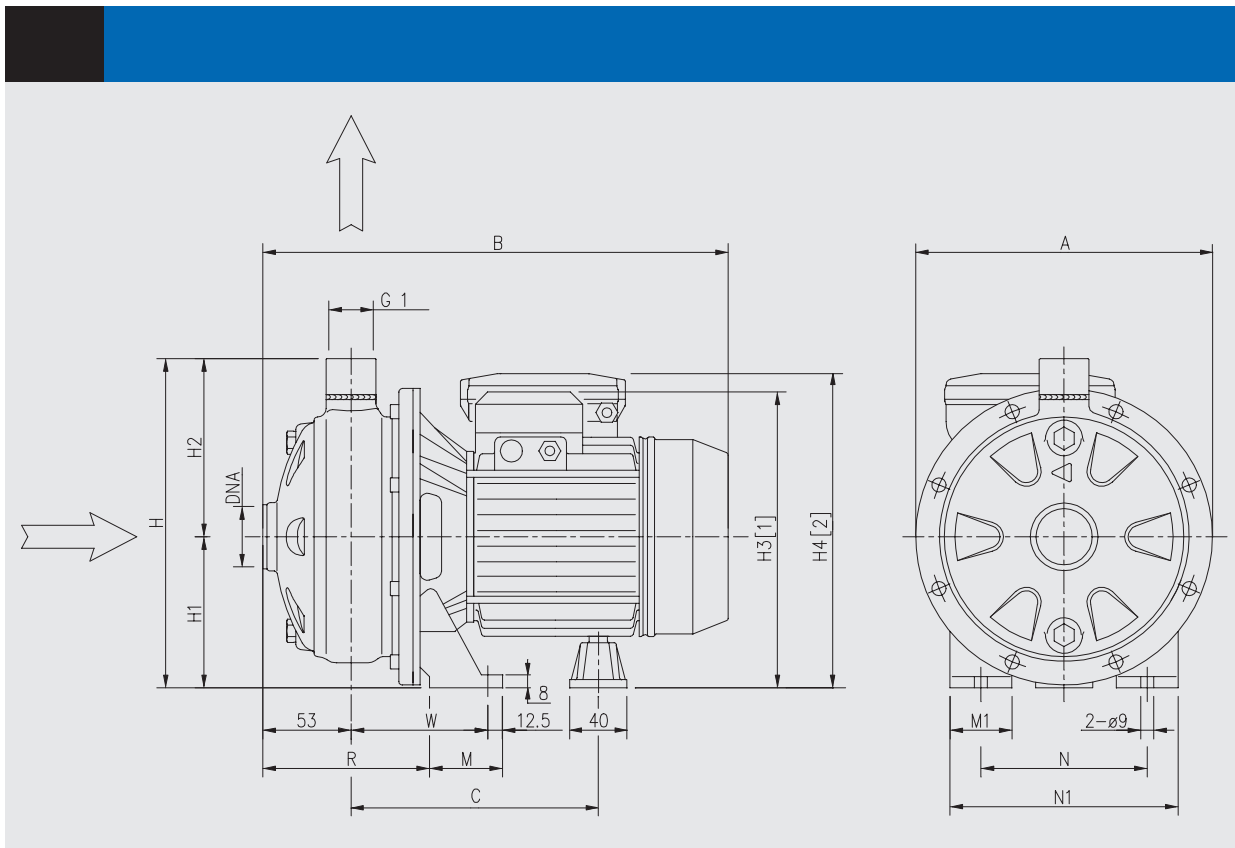

Dimensional table

Pump type CDXM - CDX		Dimensions (mm)																
		DNA	A	B		C	H	H1	H2	H3	H4	M	M1	N	N1	R	T	W
Single-phase	Three-phase			1-	3-													
CDXM 70/05	CDX 70/05	G 1 1/4	208	318	318	178	229,5	106	123,5	209	215	50	38	120	160	108	PG11	92,5
CDXM 70/07	CDX 70/07	G 1 1/4	208	318	318	178	229,5	106	123,5	209	215	50	38	120	160	108	PG11	92,5
CDXM 90/10	CDX 90/10	G 1 1/4	208	318	318	178	229,5	106	123,5	209	215	50	38	120	160	108	PG11	92,5
CDXM 120/07	CDX 120/07	G 1 1/4	208	318	318	178	229,5	106	123,5	209	215	50	38	120	160	108	PG11	92,5
CDXM 120/12	CDX 120/12	G 1 1/4	208	318	318	178	229,5	106	123,5	209	215	50	38	120	160	108	PG13,5	92,5
CDXM 120/20	CDX 120/20	G 1 1/4	232	345	345	199	250	118	132	235	253	55	40	140	180	105,5	PG13,5	95
CDXM 200/12	CDX 200/12	G 1 1/2	208	318	318	178	229,5	106	123,5	209	215	50	38	120	160	108	PG13,5	92,5
CDXM 200/20	CDX 200/20	G 1 1/2	208	345	345	199	229,5	106	123,5	223	240	55	40	140	180	105,5	PG13,5	95
	CDX 200/25	G 1 1/2	232	-	345	199	250	118	132	235	-	55	40	140	180	105,5	-	95

[1] Three-phase
[2] Single-phase



CDX

**CENTRIFUGAL PUMPS
SINGLE IMPELLER IN AISI 304**

INSTALLATIONS

ROTATION POSSIBILITIES

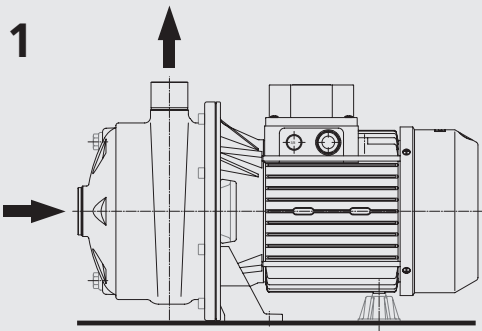

Horizontal position

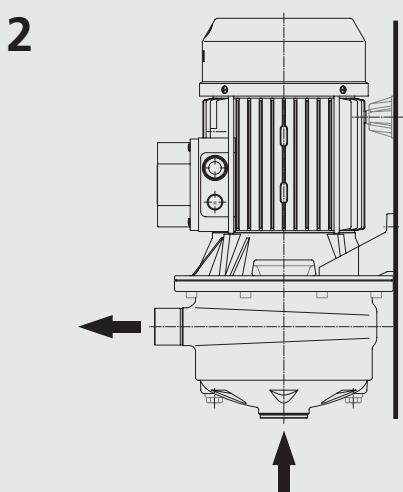

Vertical position
(please contact our sales network)

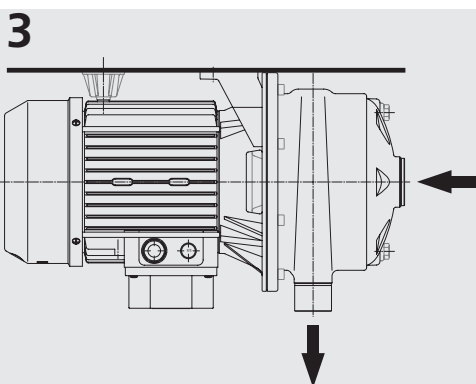

Horizontal position upside down 180°
(please contact our sales network)

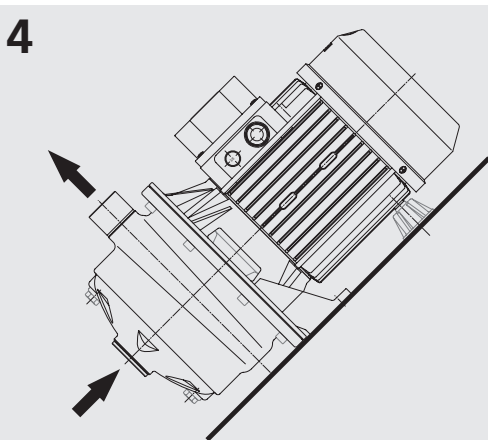

Inclined position

DISCHARGE POSITION

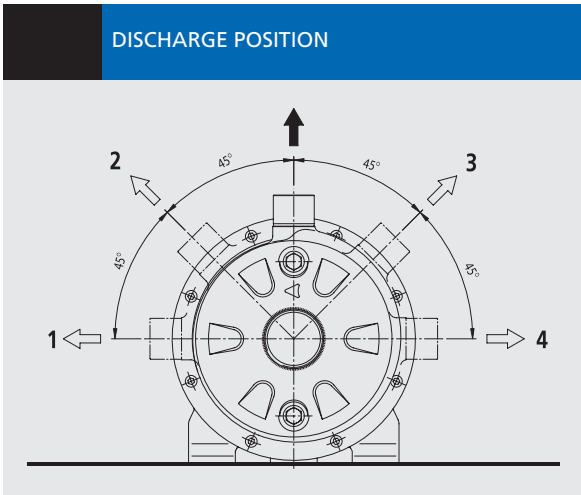

TERMINAL BOX

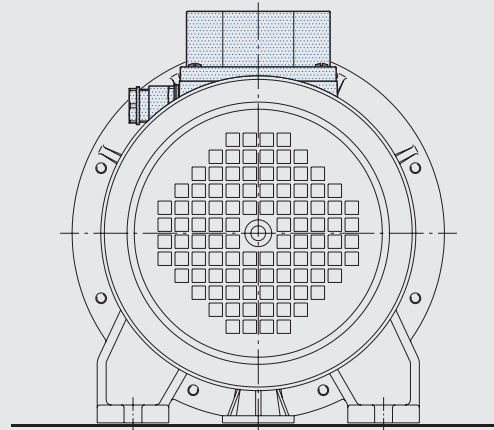

Terminal box on the delivery side standard

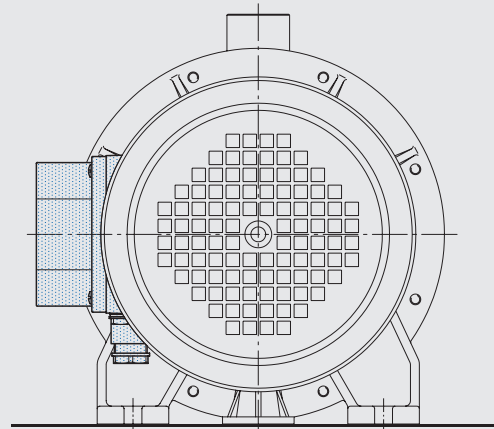

Terminal box on the left of the delivery side

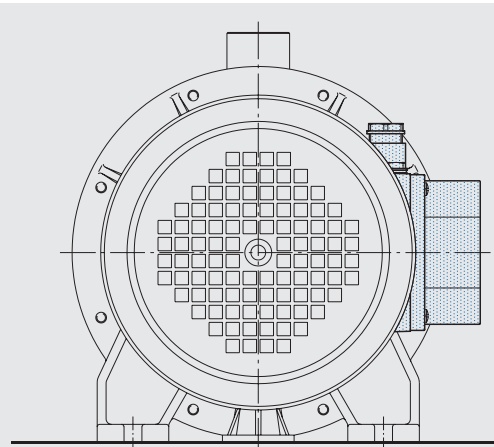

Terminal box on the right of the delivery side

2CDX

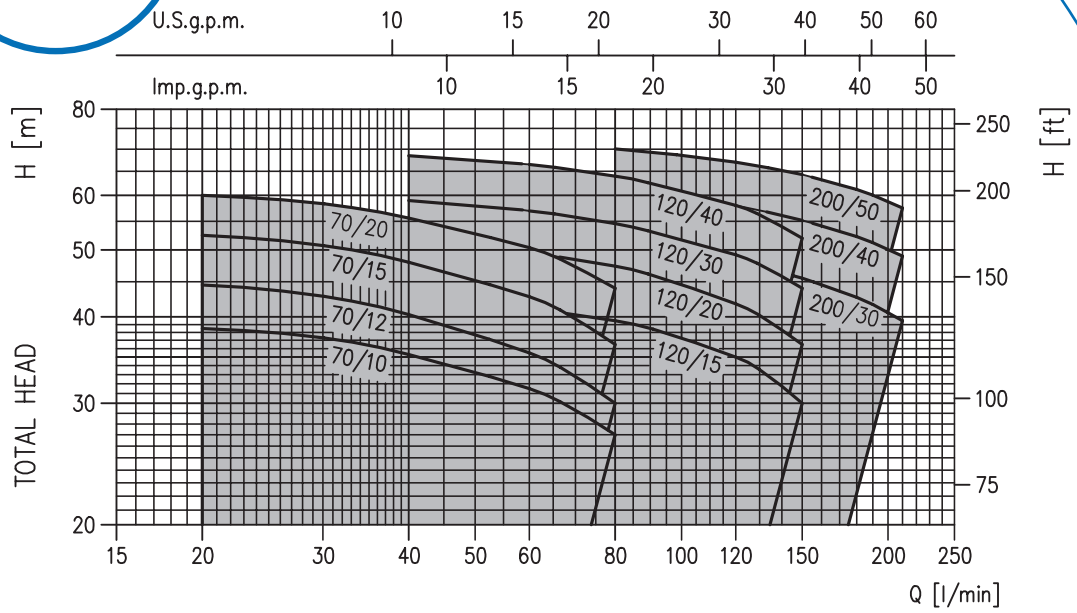

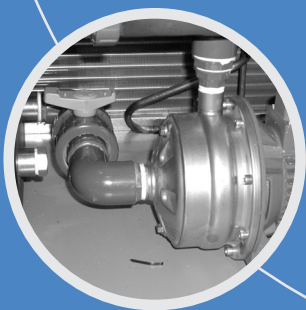
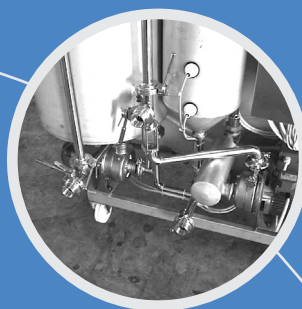
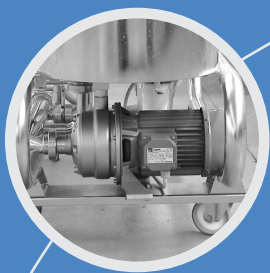

2CDX





2CDX

TWIN IMPELLER CENTRIFUGAL PUMPS IN AISI 304

SPECIFICATIONS



Twin impeller centrifugal pumps with hydraulic components constructed stainless steel AISI 304 (316 option).

APPLICATIONS

- Washing machines
- Water treatment plants
- Conditioning plants
- Heating plants
- Enological and food plants
- Moderately aggressive fluids pumping
- Air / humidification treatment plants

TECHNICAL FEATURES

- Hydraulic robust construction
- High performances and efficiency
- Integrated volute obtained from hydro-forming process
- Silent
- Compact dimensions

TECHNICAL DATA

- Capacity up to 14.4 m³/h
- Total head up to 75 m
- T.E.F.C. 2 poles motor
- Insulation class F
- Protection degree IP55
- 1 230V ± 10% 50Hz, 3 230/400V ± 10% 50Hz
- Permanent split capacitor and automatic thermal overload protection for single-phase version
- Thermal protection to be provided by the user for three-phase version
- DNA 1" 1/2 for 2CDX200
- DNA 1" 1/4 for the other models
- DNM 1"

PERFORMANCE CHART
(according to ISO 9906 Annex A)

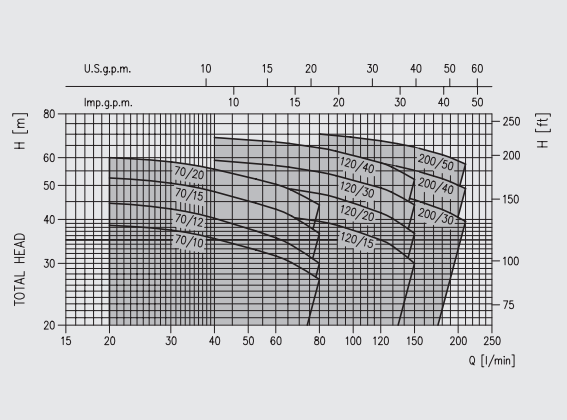

TYPE KEY

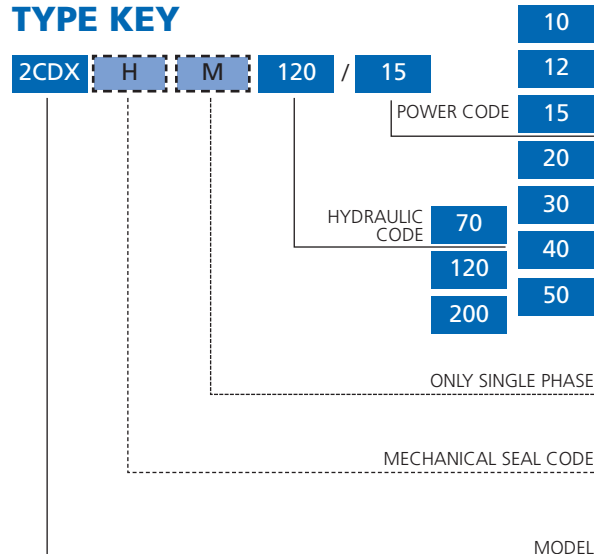

PERFORMANCE TABLE

Pump type		Power		Q=Capacity								
Single-phase	Three-phase	kW	HP	l/min	20	40	60	80	120	150	180	210
				m ³ /h	1,2	2,4	3,6	4,8	7,2	9,0	10,8	12,6
H=Total manometric head in meters												
2CDXM 70/10	2CDX 70/10	0,75	1		38,5	35,3	31,5	27	-	-	-	-
2CDXM 70/12	2CDX 70/12	0,9	1,2		44,5	40,3	35,5	30	-	-	-	-
2CDXM 70/15	2CDX 70/15	1,1	1,5		52,5	48	42,8	36,5	-	-	-	-
2CDXM 70/20	2CDX 70/20	1,5	2		60	55,6	50,4	44	-	-	-	-
2CDXM 120/15	2CDX 120/15	1,1	1,5		-	42	41	39,5	35	30	-	-
2CDXM 120/20	2CDX 120/20	1,5	2		-	51,5	49,5	47,4	41,8	36,5	-	-
-	2CDX 120/30	2,2	3		-	59	57	54,6	49,2	44	-	-
-	2CDX 120/40	3	4		-	68,5	66,5	64	58	52	-	-
-	2CDX 200/30	2,2	3		-	-	52	50,8	48,1	45,5	42,7	39,5
-	2CDX 200/40	3	4		-	-	62,5	61,1	58	55,2	52,3	49
-	2CDX 200/50	3,7	5,5		-	-	71,5	70,1	67	64,3	61,2	57,5

TWIN IMPELLER CENTRIFUGAL PUMPS
IN AISI 304

2CDX

SPECIFICATIONS



PUMP		
Liquid Handled	Type of liquid	Clean water
	Max temperature [°C]	60 standard
		110 (2CDXH and 2CDXHS)
	Min temperature [°C]	-10 standard
Maximum working pressure	[MPa]	0.8
Construction	Impeller	Closed centrifugal type
	Shaft seal type	Mechanical seal
	Bearing	Sealed ball bearing
Pipe Connection	Suction	G 1¼ G 1½ (2CDX200)
	Discharge	G 1
Material	Casing	AISI 304
	Impeller	AISI 304
	Casing cover	AISI 304
	Shaft seal	Ceramic/Carbon/NBR (2CDX) Standard
		Ceramic/Carbon/FPM (2CDXH)
		SiC/SiC/FPM (2CDXHS)
	Shaft	AISI 304 (Wet extension)
	Bracket	Aluminium (up to 1.5 kW included)
Cast iron (2.2 kW and above)		
Diffuser	AISI 304	

MOTOR			
Type		Electric - TEFC	
		Single Phase	Three Phase
No. of Poles		2	
Rotation speed	[min-1]	≈ 2800	
Insulation Class		Class F	
Protection degree		IP 55	
Power rating	[kW]	0.75 ÷ 1.5	0.75 ÷ 4
	[HP]	1 ÷ 2	1 ÷ 5.5
Frequency	[Hz]	50	
Voltage	[V]	230 ±10%	230/400 ±10%
Capacitor		Built in	-
Over load protection		Built in	Provided by the user
Casing material		Aluminium	
Base material/motor support		Aluminium	

SPECIFICATION OF MATERIALS AND MOTORS

Standard motors for ambient temperatures till 40°C and altitude till 1000 m.
For different applications, please contact our Sales Network.



2CDX

TWIN IMPELLER CENTRIFUGAL PUMPS IN AISI 304

ELECTRICAL DATA

ELECTRICAL DATA

TYPE PUMPS		POWER		CAPACITOR		POWER INPUT		FULL LOAD CURRENT		
Single Phase 230 V 50 Hz	Three Phase 230/400 V 50 Hz	kW	HP	Single Phase µF	Vc	Single Phase	Three Phase	Single Phase	Three Phase	
									230 V	400 V
2CDXM 70/10	2CDX 70/10	0.75	1	20	450	1,30	1,18	6,0	4,0	2,3
2CDXM 70/12	2CDX 70/12	0.9	1,2	31,5	450	1,50	1,50	7,0	5,0	2,9
2CDXM 70/15	2CDX 70/15	1.1	1,5	35	450	1,80	1,64	8,0	5,6	3,2
2CDXM 70/20	2CDX 70/20	1,5	2	40	450	2,30	2,20	9,9	7,0	4,0
2CDXM 120/15	2CDX 120/15	1,1	1,5	35	450	1,80	1,70	8,3	5,6	3,2
2CDXM 120/20	2CDX 120/20	1,5	2	40	450	2,35	2,20	10,2	7,0	4,0
-	2CDX 120/30	2,2	3	-	-	-	2,85	-	8,7	5,0
-	2CDX 120/40	3	4	-	-	-	3,50	-	10,8	6,2
-	2CDX 200/30	2,2	3	-	-	-	3,05	-	10,4	6,0
-	2CDX 200/40	3	4	-	-	-	3,85	-	11,4	6,6
-	2CDX 200/50	3,7	5	-	-	-	4,60	-	15,0	8,7

SOUND PRESSURE LEVEL EMITTED BY ELECTRO-PUMPS

Power kW	MOTOR		50 Hz LpA - dB (A)	60 Hz LpA - dB (A)*
	Size Mec			
0.37	71		61	65
0.55	71		62	66
0.75	71		62	66
0.9	71		62	66
1.1	80		64	68
1.5	80		64	68
1.85	80		65	--
2.2	90		68	72
3	90		68	72
4	100		--	77

* Mean value of several measures at 1m distance around the pump. Tolerance ± 2.5 dB.

2CDX

TWIN IMPELLER CENTRIFUGAL PUMPS IN AISI 304

PERFORMANCE CURVES



CDX 70/10 (0.75 kW) Impeller diameter = 132/132
 CDX 70/12 (0.90 kW) Impeller diameter = 132/153
 CDX 70/15 (1.10 kW) Impeller diameter = 153/153
 CDX 70/20 (1.50 kW) Impeller diameter = 153/176

2800 m¹

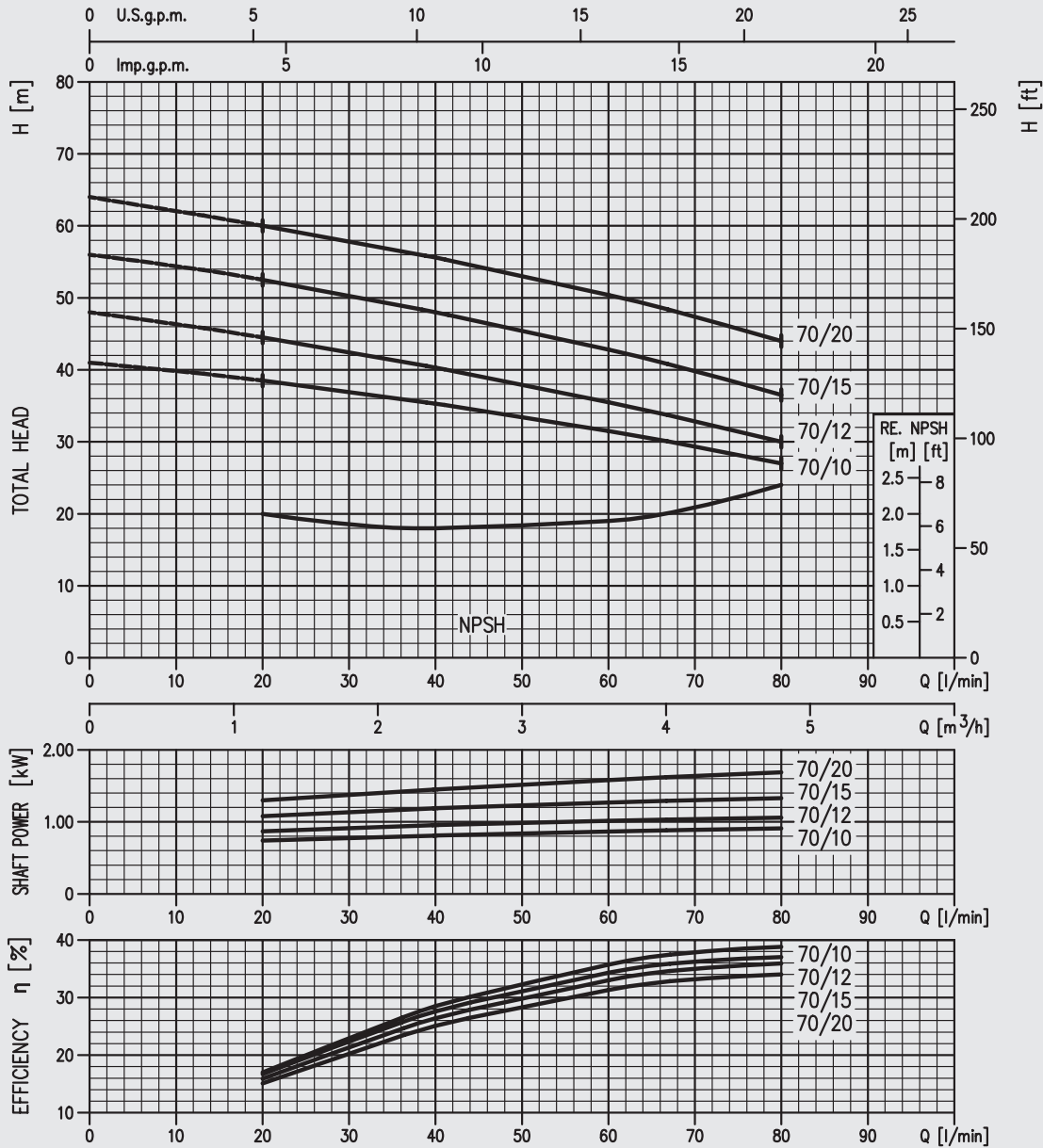

The hydraulic performances indicated refer to the tests executed with water at 20°C according to standard ISO 9906, annex A. On the values of NPSH indicated, we suggest you to add a security margin of 0,5 m. in order to guarantee the practical working.



2CDX

TWIN IMPELLER CENTRIFUGAL PUMPS IN AISI 304

PERFORMANCE CURVES

2CDX 120/15 (1.10 kW) Impeller diameter = 132/132
 2CDX 120/20 (1.50 kW) Impeller diameter = 132/157
 2CDX 120/30 (2.20 kW) Impeller diameter = 157/157
 2CDX 120/40 (3.00 kW) Impeller diameter = 157/176

2800 m⁻¹

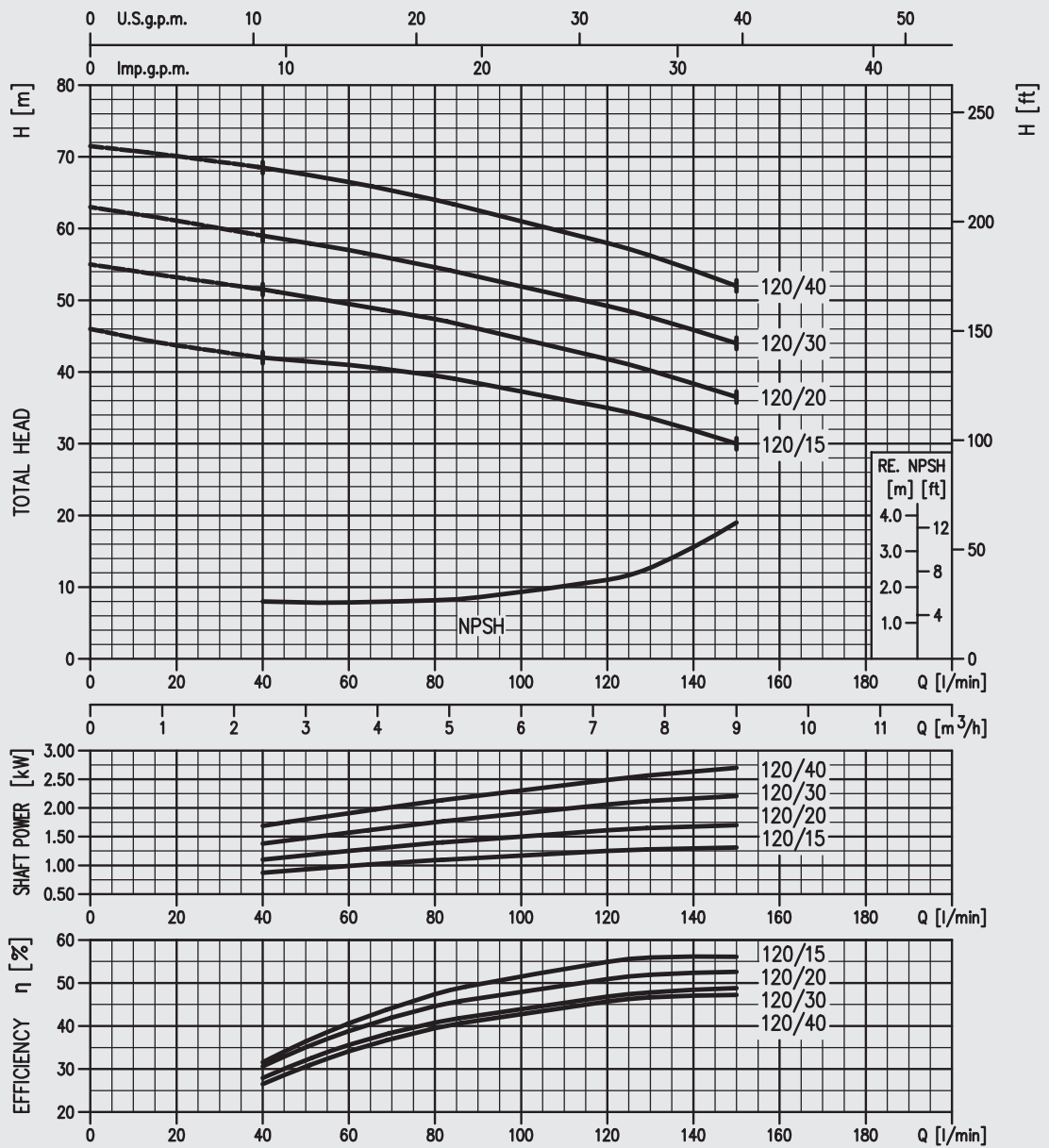

2CDX

TWIN IMPELLER CENTRIFUGAL PUMPS IN AISI 304

PERFORMANCE CURVES



2CDX 200/30 (2.20 kW) Impeller diameter = 132/157
2CDX 200/40 (3.00 kW) Impeller diameter = 157/157
2CDX 200/50 (3.70 kW) Impeller diameter = 157/176

2800 m¹

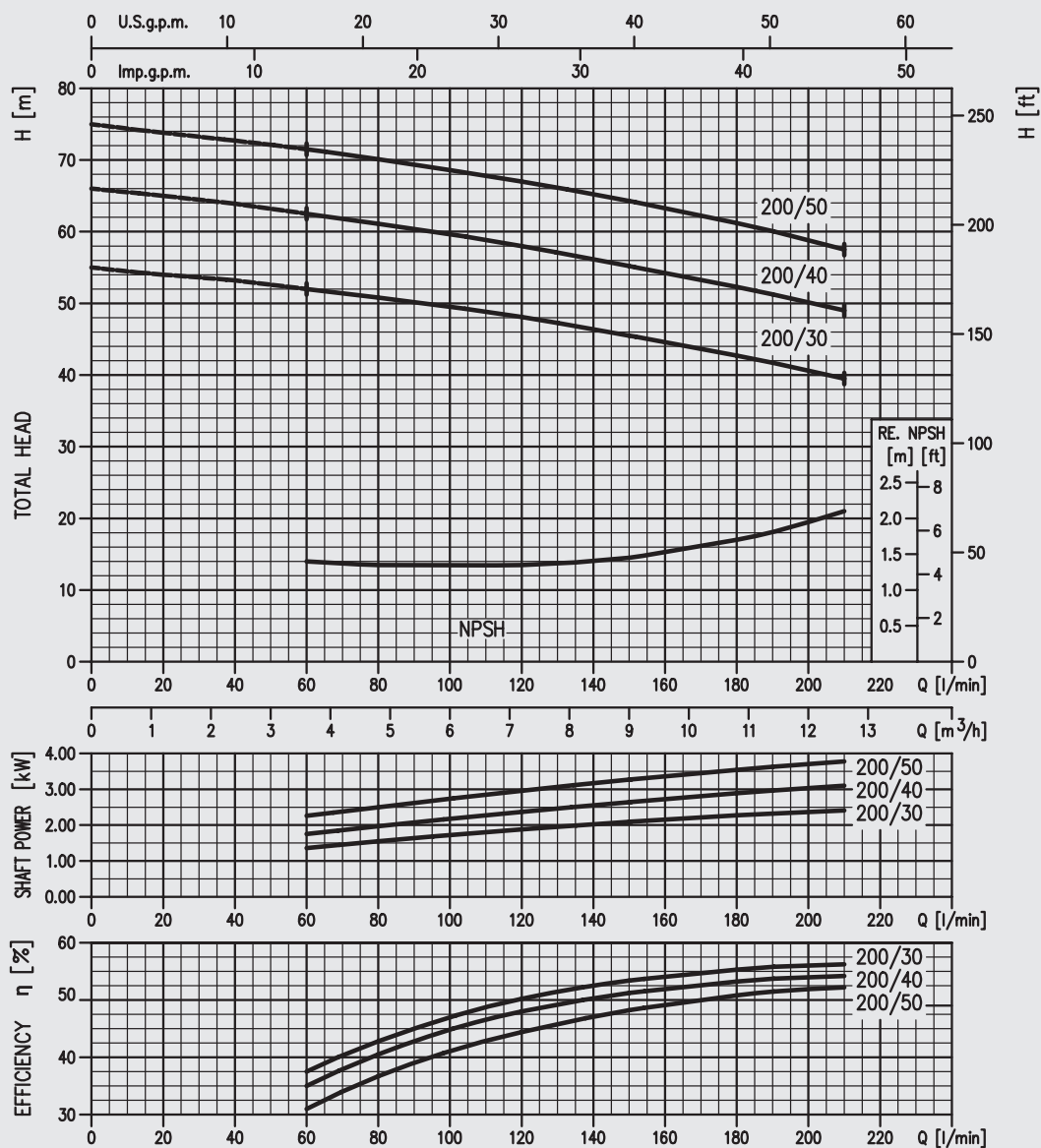



2CDX

TWIN IMPELLER CENTRIFUGAL PUMPS IN AISI 304

SECTIONAL VIEW

EXPLODED VIEW AND LIST OF COMPONENTS

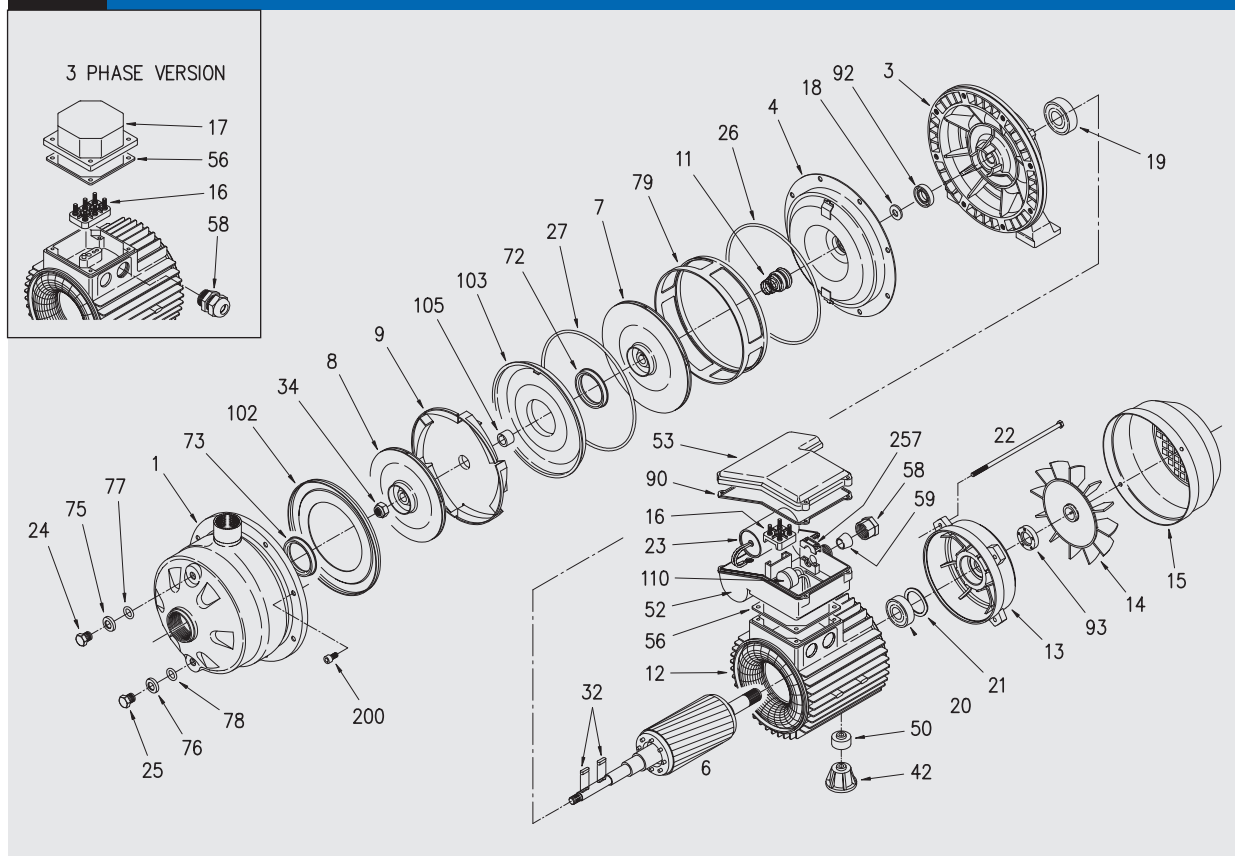

N°	PART NAME	MATERIAL	Q.TY	N°	PART NAME	MATERIAL	Q.TY
1	Casing	AISI 304	1	25	Drain plug	AISI 303	1
3	Motor bracket	Aluminium (up to 1.5 kW included) Cast iron (for 2.2 kW, and above)	1	26	O-ring	NBR [3]	1
27				O-ring	NBR [3]	1	
32				Key	AISI 304	2	
34				Impeller nut	AISI 304	1	
4	Casing cover	AISI 304	1	42	Motor support	Aluminium	1
6	Shaft with rotor	AISI 303 (Part in contact with liquid)	1	52	Terminal box [1]	Polypropilene	1
7	Impeller	AISI 304	1	53	Terminal box cover [1]	Polypropilene	1
8	Impeller	AISI 304	1	56	Box gasket	NBR	1
9	Diffuser	AISI 304	1	72	Casing ring	NBR [3]	1
11	Mechanical seal	Carbon/Ceramic/NBR [3]	1	73	Casing ring	NBR [3]	1
12	Motor frame with stator	-	1	75	Washer	AISI 304	1
13	Motor cover	Aluminium	1	76	Washer	AISI 304	1
14	Fan	Polypropilene	1	77	O-ring	NBR [3]	1
15	Fan cover	Fe P04 Zinked	1	78	O-ring	NBR [3]	1
16	Terminal box	-	1	79	Space diffuser	AISI 304	1
17	Terminal box cover [2]	Aluminium	1	90	Cover gasket [1]	NBR	1
18	Splash ring	NBR	1	92	Lip seal	-	1
19	Pump side ball bearing	-	1	93	Lip seal	-	1
20	Fan side ball bearing	-	1	102	Suction cover	AISI 304	1
21	Adjusting ring	Steel C70	1	103	Conveyor cover	AISI 304	1
22	Tie rod	Fe 42 Zinked	4	105	Sleeve	AISI 304	1
23	Capacitor [1]	-	1	110	Protector [1]	-	1
24	Priming plug	AISI 303	1	200	Screw	Stainless steel A2 UNI7323	8

[1] Only for single phase
[2] Only for three phase
[3] FPM for 2CDXH and 2CDXHS

2CDX

TWIN IMPELLER CENTRIFUGAL PUMPS IN AISI 304

MECHANICAL SEAL



MECHANICAL SEAL

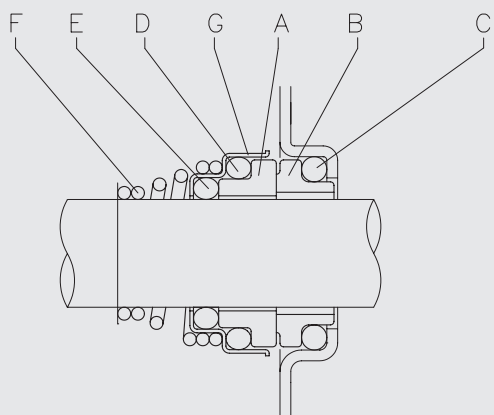

On request special mechanical seal suitable for different fluids.

REF	PART NAME	MATERIAL		
		Standard version (2CDX)	(2CDXH) Optional	(2CDXHS)
A	Rotary seal ring	Ceramic	Ceramic	Silicon carbide
B	Stationary seal ring	Carbon graphite	Carbon graphite	Silicon carbide
C	O Ring	NBR	FPM	FPM
D	O Ring	NBR	FPM	FPM
E	O Ring	NBR	FPM	FPM
F	Self driving spring	AISI 316	AISI 316	AISI 316
G	Frame	AISI 304	AISI 304	AISI 316



2CDX

TWIN IMPELLER CENTRIFUGAL PUMPS IN AISI 304

DIMENSIONS

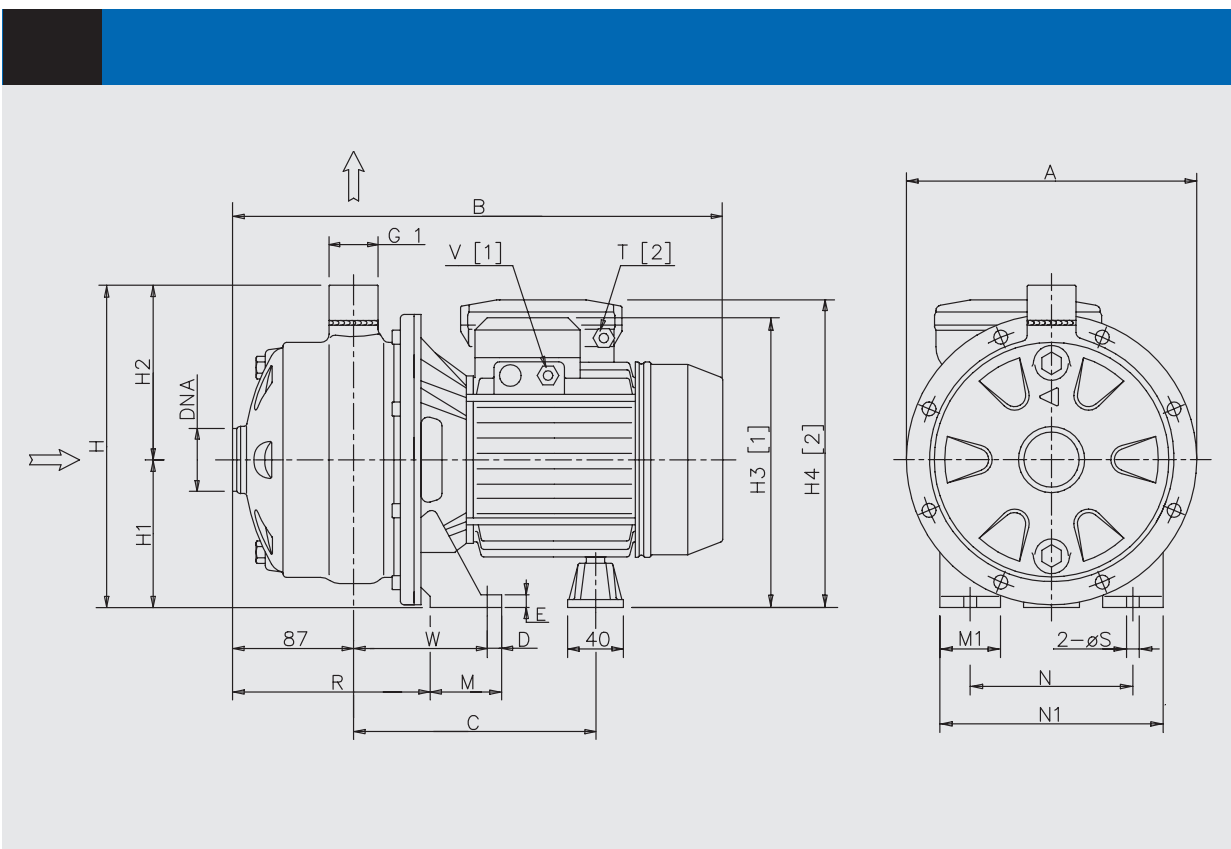

Dimensional table

Pump type 2CDXM 2CDX	Dimensions (mm)																			
	DNA	A	B	C	D	E	H	H1	H2	H3	H4	M	M1	N	N1	R	T	V	W	S
2CDXM 70/10	G 1 1/4	208	355	169	12.5	8	229	106	123	206	210	50	38	120	160	142,5	PG11	PG11	93	9
2CDXM 70/12	G 1 1/4	208	355	169	12.5	8	229	106	123	206	231	50	38	120	160	142,5	PG13,5	PG11	93	9
2CDXM 70/15	G 1 1/4	232	385	199	12.5	8	250	118	132	238	251	55	40	140	180	140	PG13,5	PG11	95	9
2CDXM 70/20	G 1 1/4	232	385	199	12.5	8	250	118	132	238	251	55	40	140	180	140	PG13,5	PG11	95	9
2CDXM 120/15	G 1 1/4	208	380	199	12.5	8	229	106	123	226	239	55	40	140	180	140	PG13,5	PG11	95	9
2CDXM 120/30	G 1 1/4	208	380	199	12.5	8	229	106	123	226	239	55	40	140	180	140	PG13,5	PG11	95	9
2CDXM 120/40	G 1 1/4	232	393	210	12.5	8	250	118	132	242	-	65	40	140	180	144	-	PG13,5	109	9
2CDXM 200/30	G 1 1/4	232	394	210	12.5	8	250	118	132	242	-	65	40	140	180	144	-	PG13,5	109	9
2CDXM 200/40	G 1 1/2	208	394	210	12.5	8	229	106	123	230	-	65	40	140	180	144	-	PG13,5	109	9
2CDXM 200/50	G 1 1/2	232	394	210	12.5	8	250	118	132	242	-	65	40	140	180	144	-	PG13,5	109	9
2CDXM 200/50	G 1 1/2	232	450	236	16	13	250	118	132	255	-	68	50	160	210	144	-	PG16	109	12

[1] Three phase

[2] Single phase

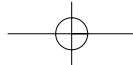

2CDX

TWIN IMPELLER CENTRIFUGAL PUMPS IN AISI 304

INSTALLATIONS



ROTATION POSSIBILITIES

1

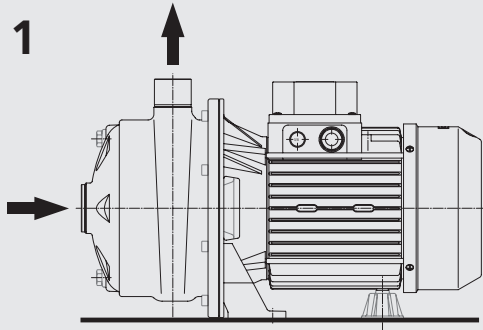

Horizontal position

2

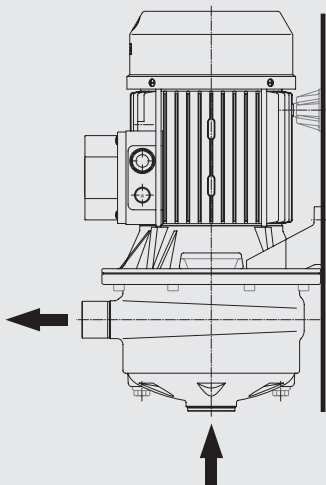

Vertical position
(please contact our sales network)

3

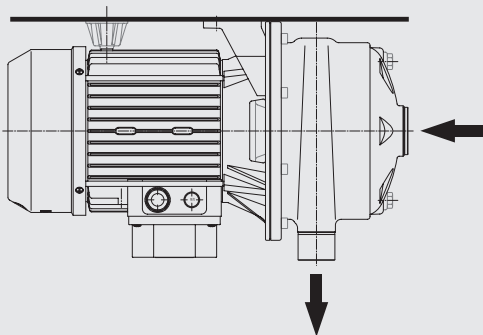

Horizontal position upside down 180°
(please contact our sales network)

4

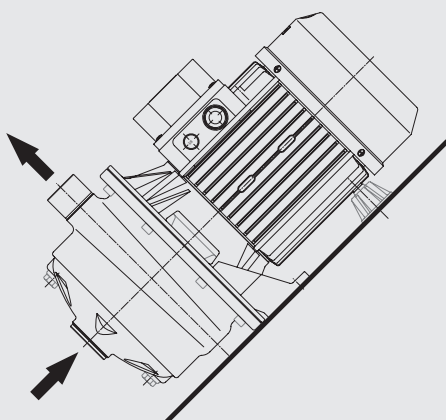

Inclined position

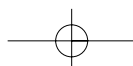



2CDX

TWIN IMPELLER CENTRIFUGAL PUMPS IN AISI 304

INSTALLATIONS

DISCHARGE POSITION

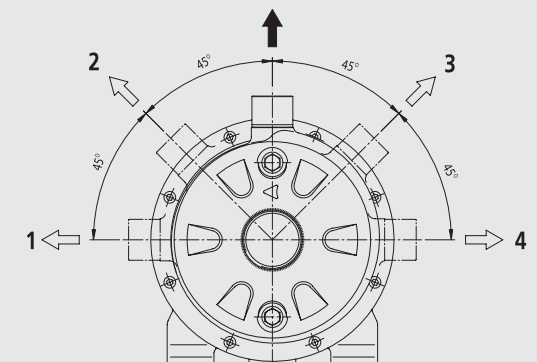

TERMINAL BOX

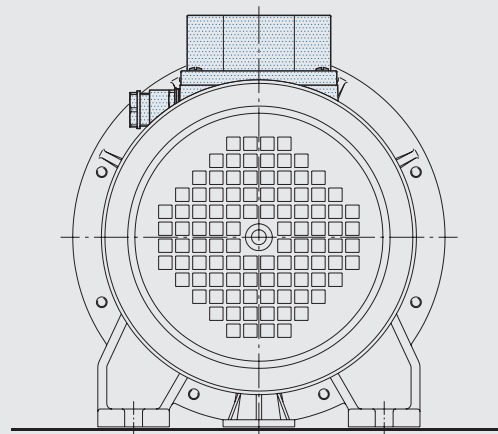

Terminal box on the delivery side standard

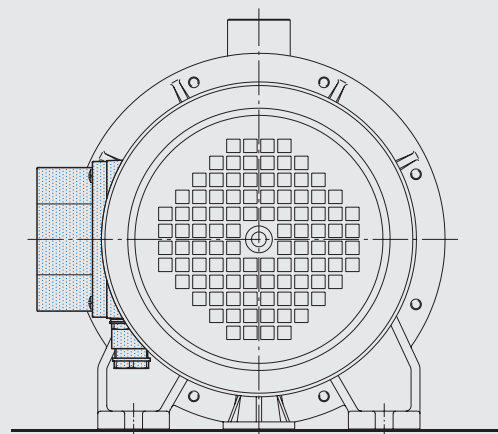

Terminal box on the left of the delivery side

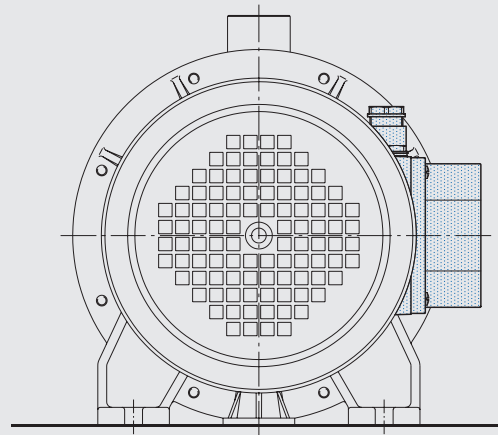

Terminal box on the right of the delivery side



Let Our
Excellence
Be Yours

www.ebara.eu



EBARA PUMPS EUROPE S.p.A.
Via Pacinotti, 32
36040 BRENDOLA (VICENZA), Italy
Phone: +39-0444-706811
Fax: +39-0444-706950
Plants: Cles, Brendola
www.ebara.eu

cod. 479705356 REV. 01/05

EBARA PUMPS EUROPE S.p.A. reserves the right to make modifications without prior notice: all specifications could be subject to change