

Twin impeller centrifugal pumps with hydraulic components constructed in stainless steel AISI 304, suitable for pressure boosting, water supply, water treatment and irrigation. Air conditioning systems and general water pumping including moderately aggressive liquids

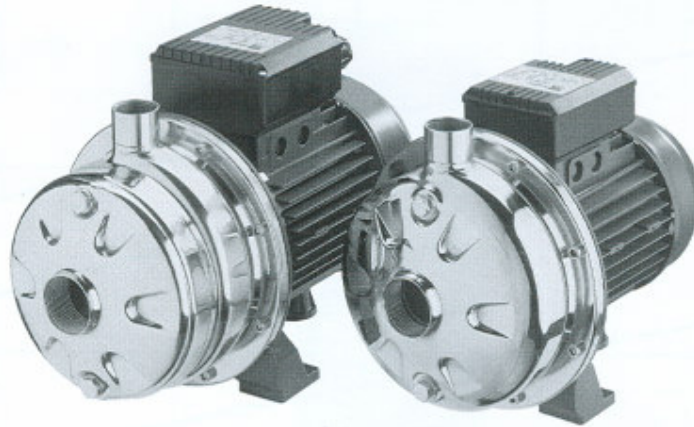

SPECIFICATIONS

- Max working pressure: 8 bar
- Max. water temperature: 60°C 2CDX
110°C 2CDXH - 2CDXHS

MATERIALS

- Pump body, impeller, diffuser and casing cover in AISI 304
- Shaft in AISI 303
- Bracket and motor casing in aluminium
- Mechanical seal in carbon/ceramic/NBR
- Special mechanical seal are available on demand

TECHNICAL DATA

- T.E.F.C. 2 poles motor
- Insulation class F
- Protection degree IP 55
- Single-phase standard voltage: 220-230V $\pm 6\%$
110-115V $\pm 6\%$
- Three-phase standard voltage: 220/380V -6% +10%
- Permanent split capacitor and automatic thermal overload protection for single-phase version
- Thermal protection to be provided by the user for three-phase version
- DNA 1 $\frac{1}{2}$ " for 2CDX 200
- DNA 1 $\frac{1}{4}$ " for other models
- DNM 1"

DIMENSIONS

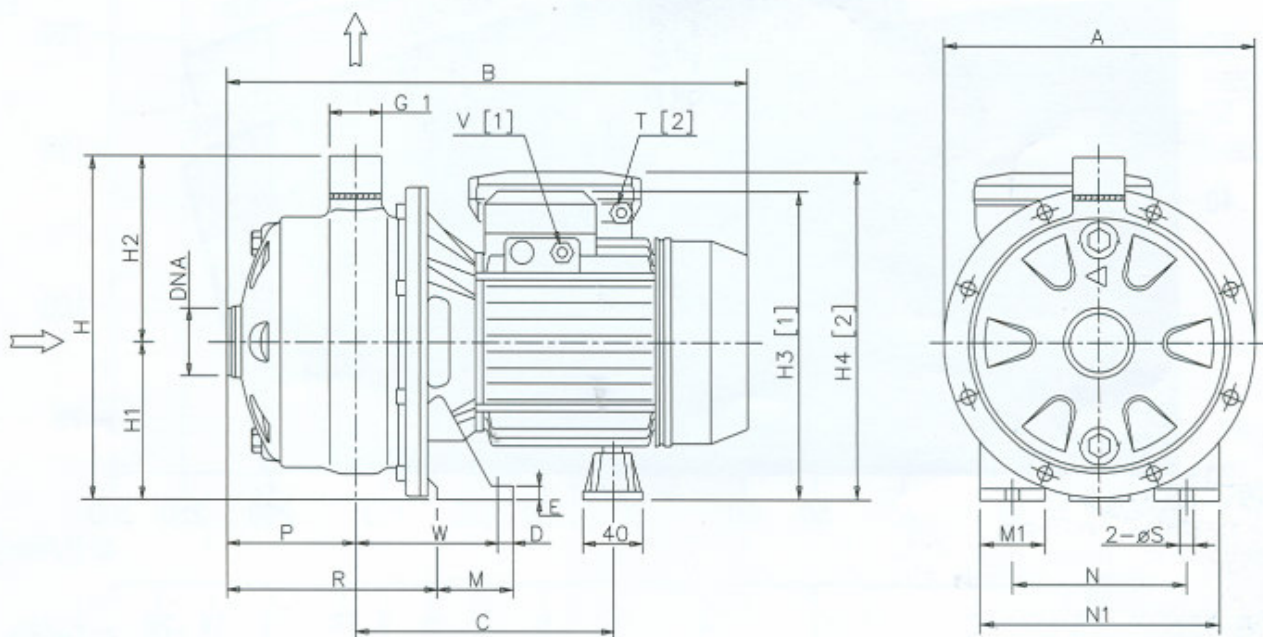

DIMENSIONAL TABLE

| Pump type 2CDX(M) | Dimensions [mm] | | | | | | | | | | | | | | | | | | | | Weight [kg] | | | |
|----------------------|-----------------|-------|-----|-------|------|----|-----|-----|-----|-------|-------|----|----|-----|-----|----|-------|-----|---------|---------|----------------|-------|------|------|
| | A | B | | C | D | E | H | H1 | H2 | H3 | H4 | M | M1 | N | N1 | P | R | S | T | V | W | DNA | 1~ | 3~ |
| 70/106 | 208 | 357,5 | 358 | 181 | 12,5 | 8 | 229 | 106 | 123 | 207 | 211 | 50 | 38 | 120 | 160 | 87 | 141 | Ø9 | PG 11 | PG 11 | 93 | G 1"¼ | 12,6 | 12 |
| 70/206 | 208 | 380 | 393 | 199,5 | 12,5 | 8 | 229 | 106 | 123 | 221,5 | 242,5 | 55 | 40 | 140 | 180 | 87 | 139,5 | Ø9 | PG 13,5 | PG 11 | 95 | G 1"¼ | 16,6 | 16 |
| 70/306 | 208 | 380 | 393 | 199,5 | 12,5 | 8 | 229 | 106 | 123 | 221,5 | 242,5 | 55 | 40 | 140 | 180 | 87 | 139,5 | Ø9 | PG 13,5 | PG 11 | 95 | G 1"¼ | 16,9 | 16 |
| 120/206 | 208 | 395 | - | 199,5 | 12,5 | 8 | 229 | 106 | 123 | 221,5 | - | 55 | 40 | 140 | 180 | 89 | 141,5 | Ø9 | - | PG 11 | 95 | G 1"¼ | - | 15,6 |
| 120/306 | 208 | 395 | - | 199,5 | 12,5 | 8 | 229 | 106 | 123 | 221,5 | - | 55 | 40 | 140 | 180 | 89 | 141,5 | Ø9 | - | PG 11 | 95 | G 1"¼ | - | 16,7 |
| 120/406 | 208 | 418,5 | - | 234,5 | 12,5 | 11 | 229 | 106 | 123 | 226,5 | - | 65 | 40 | 140 | 180 | 89 | 145,5 | 9,4 | - | PG 13,5 | 109 | G 1"¼ | - | 23,6 |
| 200/406 | 208 | 416,5 | - | 234,5 | 12,5 | 11 | 229 | 106 | 123 | 226,5 | - | 65 | 40 | 140 | 180 | 87 | 143,5 | 9,4 | - | PG 13,5 | 109 | G 1"¼ | - | 23,4 |
| 200/506 | 208 | 445 | - | 230,5 | 16 | 13 | 241 | 118 | 123 | 253,5 | - | 68 | 50 | 160 | 210 | 87 | 143,5 | 12 | - | PG 16 | 108,5 | G 1"¼ | - | 30 |

PERFORMANCE CURVES 2CDX series (according to ISO 9906 Annex A)

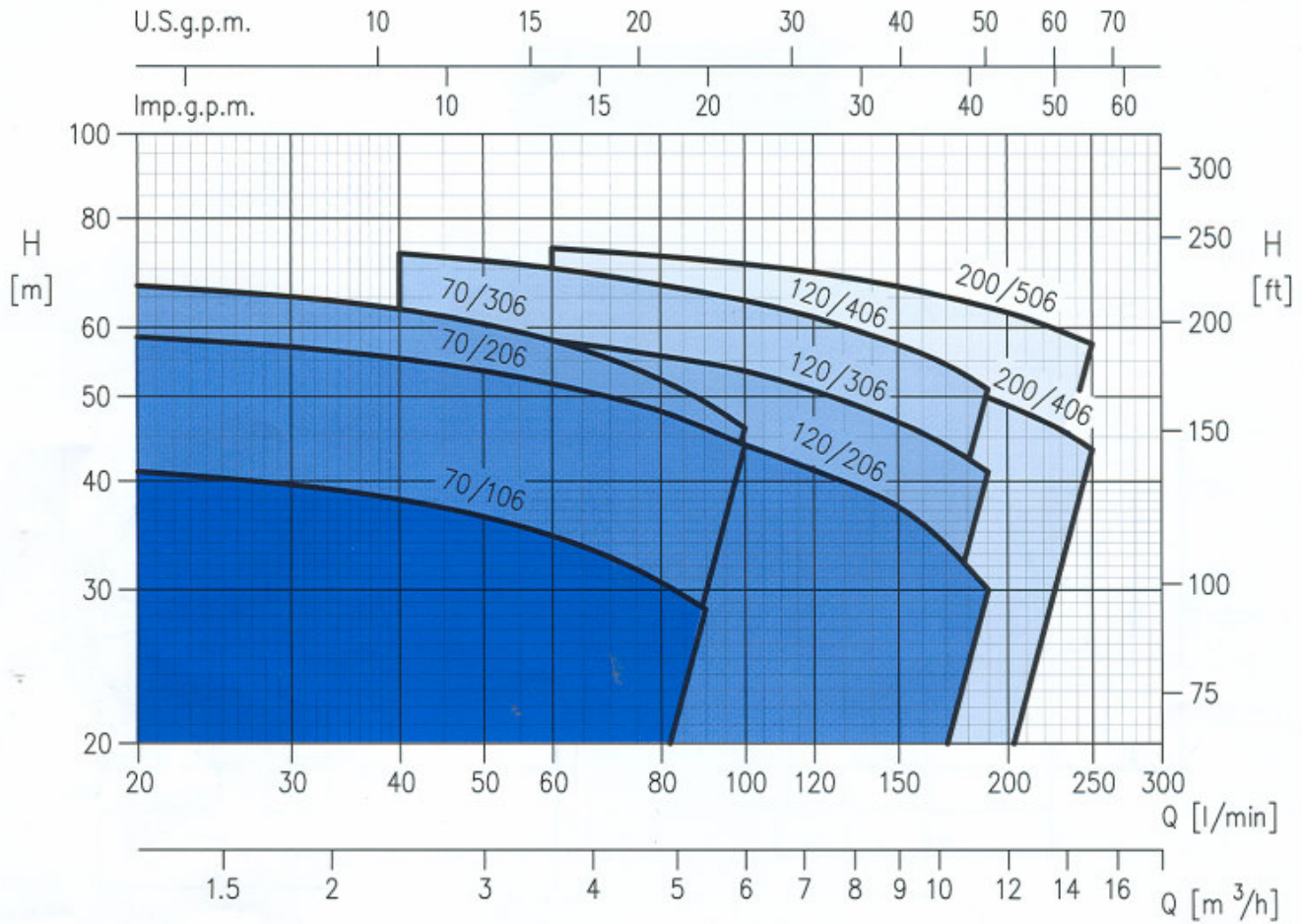

PERFORMANCE TABLE

| Pump Type 2CDX | | Output | | Absorbed current [A] | | | Q=Capacity | | | | | | | | | | | |
|-------------------|--------------|--------|-----|--------------------------|---------------------|------|-----------------------------------|------|------|------|------|------|------|------|------|------|------|------|
| | | | | | | | H=Total manometric head in meters | | | | | | | | | | | |
| Single-phase | Three-phase | kW | HP | Single-phase 220-230V | Three-phase 220V | 380V | 0 | 20 | 40 | 50 | 60 | 80 | 90 | 100 | 140 | 160 | 190 | 250 |
| | | | | | | | m³/h | 0 | 1,2 | 2,4 | 3 | 3,6 | 4,8 | 5 | 6 | 8 | 10 | 11,4 |
| 2CDXM 70/106 | 2CDX 70/106 | 0,75 | 1 | 6,4 | 3,6 | 2,1 | 43 | 41 | 38,1 | 36,4 | 34,6 | 30,6 | 28,5 | - | - | - | - | - |
| 2CDXM 70/206 | 2CDX 70/206 | 1,5 | 2 | 10,1 | 6,1 | 3,5 | 62 | 58,5 | 55,5 | 53,5 | 51,5 | 48 | 46 | 44 | - | - | - | - |
| 2CDXM 70/306 | 2CDX 70/306 | 2,2 | 3 | 11,6 | 7,1 | 4,1 | 70 | 67 | 63 | 60,5 | 58 | 52,5 | 49,5 | 46 | - | - | - | - |
| - | 2CDX 120/206 | 1,5 | 2 | - | 6,6 | 3,8 | 54,5 | - | 50,5 | 49,5 | 48,5 | 46,5 | 45 | 44 | 38,5 | 36,1 | 30 | - |
| - | 2CDX 120/306 | 2,2 | 3 | - | 8,3 | 4,8 | 64,5 | - | 60 | 59 | 58 | 55,5 | 54,5 | 53,5 | 48 | 45,5 | 41 | - |
| - | 2CDX 120/406 | 3 | 4 | - | 10,9 | 6,3 | 78 | - | 73 | 71,5 | 70 | 67,5 | 66 | 64,5 | 59 | 56 | 51 | - |
| - | 2CDX 200/406 | 3 | 4 | - | 10,4 | 6 | 65 | - | - | - | 60 | 58,5 | 57,5 | 57 | 54 | 52,5 | 50 | 43,5 |
| - | 2CDX 200/506 | 4 | 5,5 | - | 15,6 | 9 | 79 | - | - | - | 74 | 71,5 | 71,5 | 71 | 68 | 66 | 63,5 | 57,5 |

PERFORMANCE CURVES 2CDX 70 series (according to ISO 9906 Annex A)

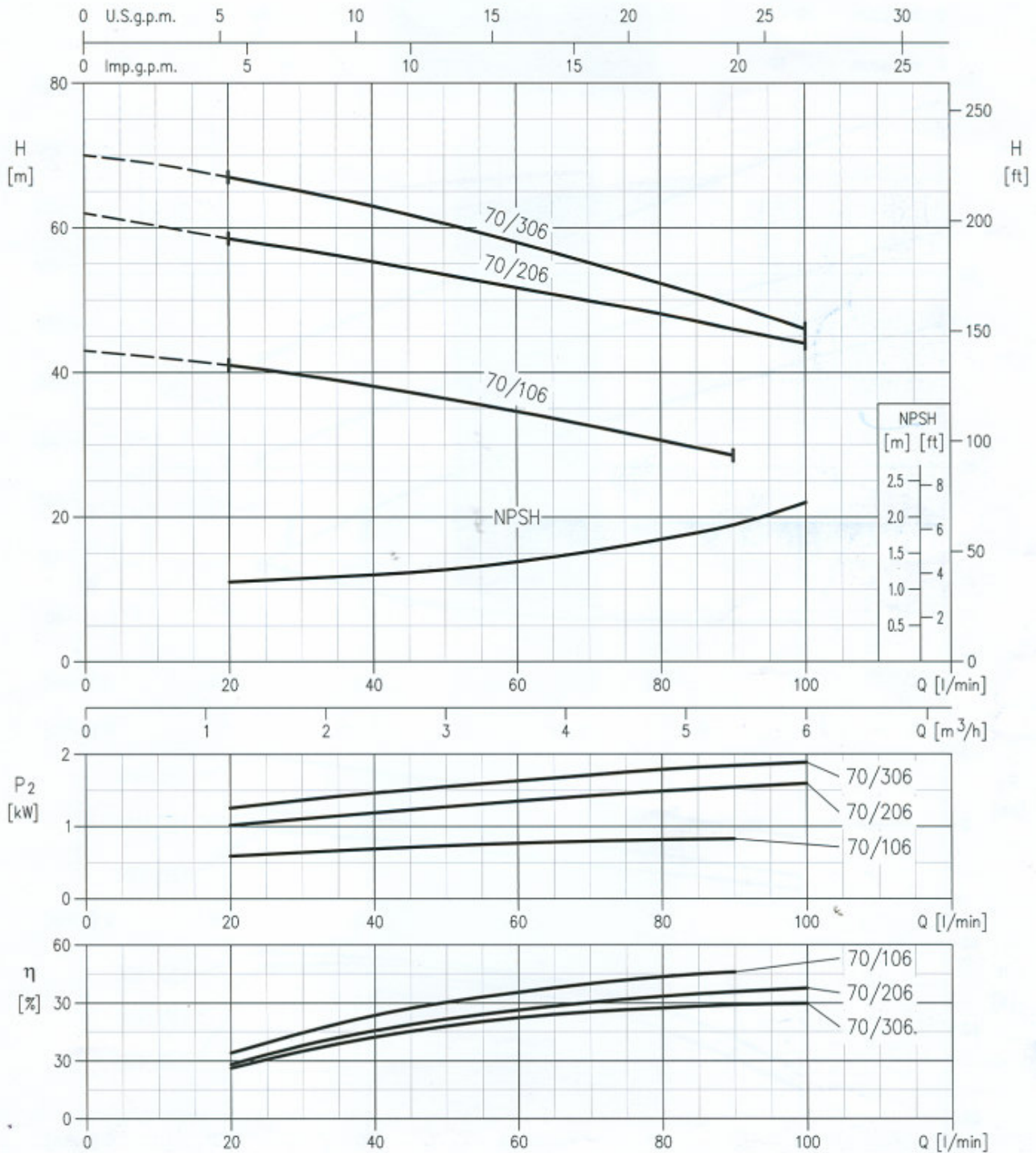

PERFORMANCE CURVES 2CDX 120 series (according to ISO 9906 Annex A)

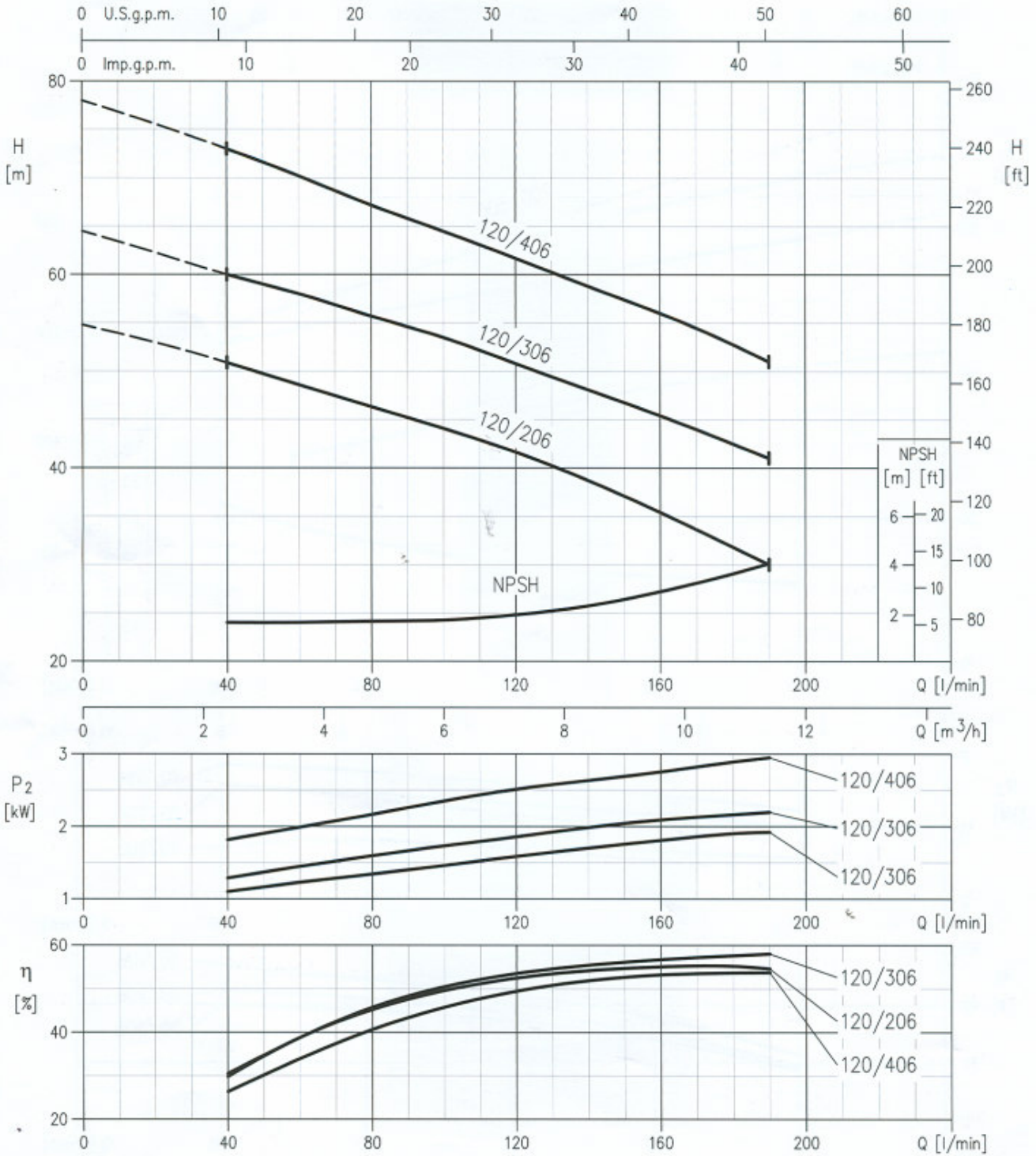

PERFORMANCE CURVES 2CDX 200 series (according to ISO 9906 Annex A)

